

900A , 25 kV & 35 kV Class Grounded Standoff Bushing



APPLICATION

The Chardon 900A 15/25 kV & 35 kV Grounded Standoff Bushings comply with the latest IEEE/ANSI 386 standard. These robust epoxy-molded bushings feature a single deadbreak interface and are ideal for grounding in pad-mount cabinets, underground vaults, and other equipment. Designed for secure

installation on a parking stand bracket, each unit includes a 60"(1.9m) 4/0 flexible copper grounding cable for a visible, submersible, and fully shielded ground connection. A stainless steel eyebolt allows for hotstick-compatible mounting and easy ground verification.

CURRENT RATINGS

Tests conducted in accordance with IEEE/ANSI Standard 386:

Current Tests	Amperes
Short Time	40,000 A rms symmetrical for 0.17s

Tests conducted in accordance with Chardon manufacturing process requirements:

- / Physical Inspection
- / Periodic Dissection
- / Periodic X-ray Analysis

ORDERING INFORMATION

Each kit Contains:

- / Grounded Standoff Bushing with Bracket
- / Shipping Cap
- / Silicone Grease
- / Installation Instruction Sheet

Deadbreak Grounded Standoff Bushing

Part Number	Description	No Stud	With Stud
25-GB900	Grounded Standoff Bushing w/ Copper Conductor	25-GB900	25-GB900S
35-GB900	Grounded Standoff Bushing w/ Copper Conductor	35-GB900	35-GB900S

PRODUCT CHARACTERISTICS

/ GROUND CABLE

60 " (1.9 m) 4 / 0 flexible , all weather 600 A copper cable, provides proper grounding.

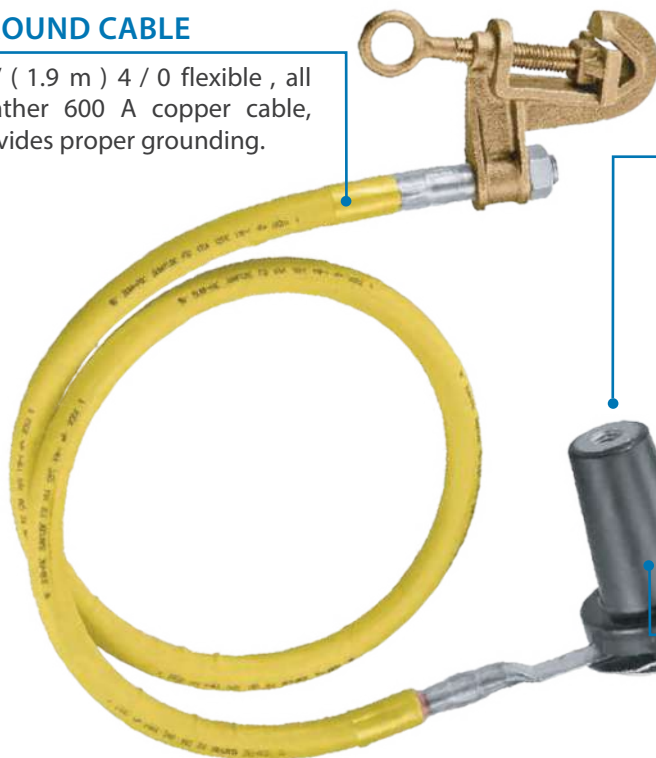

STANDARD 5/8"- 11 UNC 2B THREADS

/ Meets IEEE Standard 386-2009 specification for 600A products.

/ EYEBOLT

Stainless steel eyebolt rigidly secures standoff bushing to parking stand.

/ BRACKET

Stainless steel bracket with drain wire lug for bracket and shield grounding.

/ EPOXY INSULATION

High quality epoxy insulation ensures excellent thermal, electrical and mechanical reliability.

TECHNICAL DRAWINGS

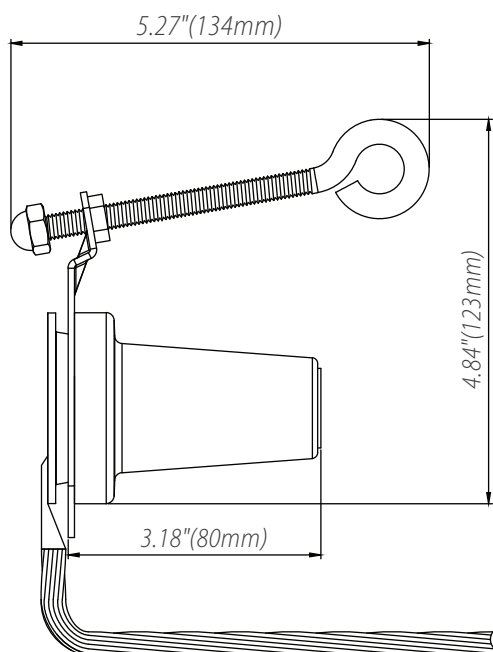

25-GB900

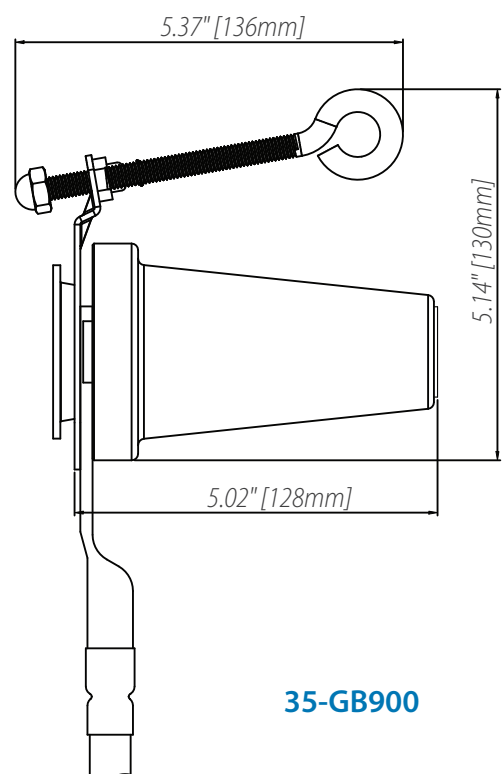

35-GB900



ANHUI CHARDON ELECTRIC LTD.

No.808 Taiji Road Economic Develop Zone of Guangde County
Anhui China
Tel: 0563-2216688
Fax: 0563-2251806

CHARDON TAIWAN CORPORATION

No.37 Min-Chie Road, Tung Lo Industrial Park, Miao Li, Taiwan 366
Tel:+886-37-984385
Fax:+886-37-984770

SHANGHAI CHARDON ELECTRIC LTD.

Room 1202, office building No.399, Yun Gu Road, Jiading district,
Shanghai, China 201801
Tel: +86-21-39105900
Fax: +86-21-39105916

www.chardongroup.com·info@chardongroup.com