

600A/900A 15/25 kV Class T-Body Deadbreak Connector



APPLICATION

Chardon 15/25-TB-600 and 15/25-TB-600T elbows are designed to terminate underground cables to high-voltage apparatus such as transformers and switchgear. They are fully shielded fully submersible and meet the requirements of IEEE Standard 386. They are interchangeable with other manufacturers products that conform with this industry standard.

The capacitive test point on the insulating plug provides a means of testing the circuit without disturbing the bolted connection. In addition to the capacitive test point feature on the insulating plug, Chardon offers an optional capacitive test point on the T-Body connector.

This allows the use of the fault indicators, and provides a hotstick operable means of determining circuit condition when used with high impedance voltage sensing devices designed for test points.

T-Body Connectors are designed for use on solid dielectric cable (XLPE or EPR) with extruded semi-conductive shields and concentric neutral, with or without a jacket. Installation on jacketed concentric neutral cable may require additional sealing material. A special grounding adapter is available for tape shield, linear corrugated, unshield, and drain wire cables for use with Deadbreak connectors.

KEY FEATURES

- / 100% factory production testing for partial discharge and AC withstand per IEEE 386.
- / Peroxide cured EPDM rubber provides low tension set and high dielectric strength.
- / Optional selection of test point installed to provide voltage indication.
- / Molded semiconducting shield provides ground shield continuity per the requirements of IEEE 592.
- / Grounding Tab and Stress Relief Cone design provide operational safety.
- / Fully meets IEEE 386–2006 specficcate.

PRODUCT RATINGS

Voltage Class	25 kV
Max. Rating Phase to Ground	15.2 kV
AC 1 Minute Withstand	40 kV
DC 15 Minute Withstand	78 kV
BILand Full Wave Crest	125 kV
Partial Discharge	21.5kV ≤5pC
Continuous	600Arms
24 Hour Overload	1,000Arms
Momentary	25,000A symmetrical 10 cycles / 10,000A symmetrical 3.00 sec

Voltage/Current ratings and characteristics are in accordance with IEEE Std 386 standard.

T-BODY KIT CONTENT

Tests conducted in accordance with IEEE Standard 386.

- / T-Body
- / Insulating Plug (Al for 600A, Cu for 900A)
- / Cable Adapter
- / Stud
- / Compression Lug (Al for 600A, Cu for 900A)
- / Silicone Grease
- / Installation Instructions Sheet

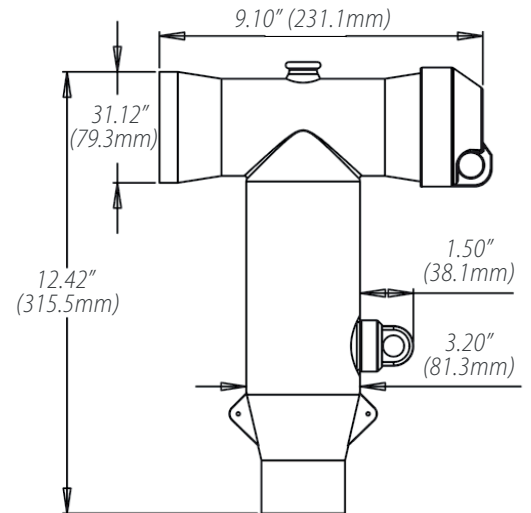
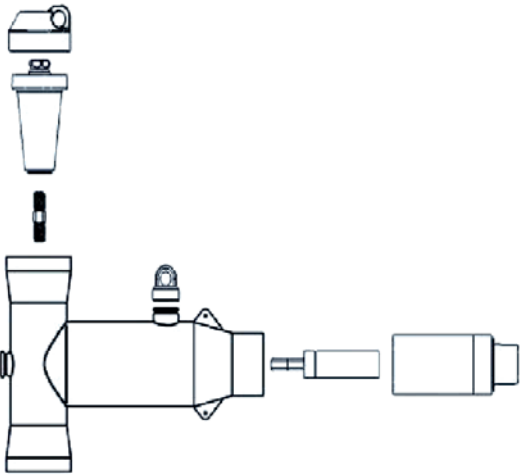

PRODUCTION TESTS

Tests conducted in accordance with IEEE Standard 386.

- / Partial Discharge - $21.5\text{kV} \leq 5\text{pC}$
- / AC 1 Minute Withstand - 40kV

Tests conducted in accordance with Chardon Manufacturing Process requirements:

- / Physical Inspection
- / Periodic Dissection
- / Periodic X-ray Analysis

DETAILED COMPOSITION OF THE CHARDON 15/25KV 600A T-BODY DEADBREAK CONNECTOR

/ T-BODY CONNECTOR BODY

Molded T-body adapts to all cable sizes and provides a dead front shielded connection.

/ SEMICONDUCTING INSERT

Precision molded peroxide cured semiconducting insert provides corona-free electrostatic shielding of the compression lug.

/ INSULATION LAYER

High quality peroxide cured EPDM Insulation is mixed and formulated in-house for complete control of rubber characteristics.

/ DRAIN WIRE TABS

Drain wire tabs provide a convenient point to connect drain wire to ensure grounding of the connector shield.

/ SEMICONDUCTING SHIELD

Precision molded peroxide cured semiconducting shield provides ground shield continuity and meets the requirements of IEEE Standard 592.

/ INSULATING PLUG

Molded epoxy insulating plug provides excellent electrical, thermal and mechanical reliability.

/ COMPRESSION LUG/ SHEAR BOLT LUG

Aluminum/Copper compression lug or shear bolt lug is sized to ensure a cool running connector with maximum current transfer.

/ CAPACITIVE TEST POINT

Capacitive test point on molded T-Body with snap-on cap provides a shielded, hotstick operable means to determine circuit condition.

/ CABLE ADAPTER

Molded cable adapter, sized to fit cable insulation diameters from 0.640 inch to 1.965 inches (16.3 to 49.9 mm), provides stress relief for the terminated cable.

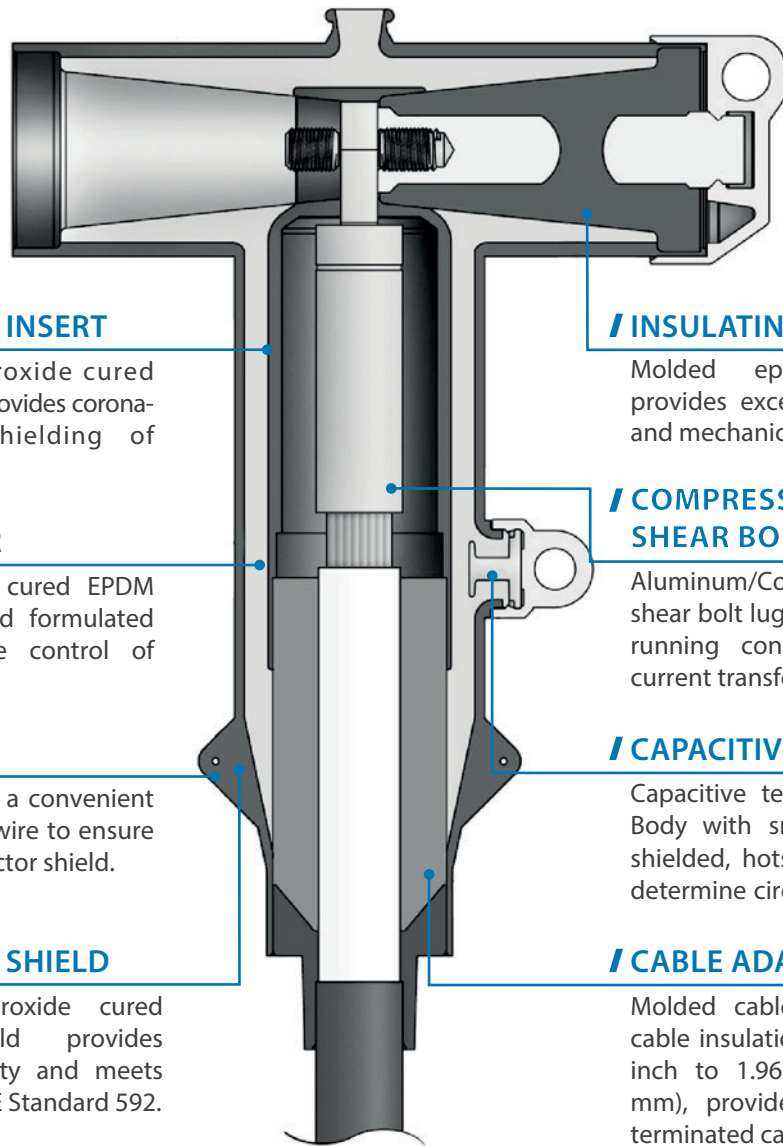

ORDERING INFORMATION

15/25-TB	- - - -	—	- - - -
	STEP1	STEP2	STEP3

STEP1

Selection of Current Rating

Code	Description
600T	600AMP WITH Test Point
900T	900AMP WITH Test Point

Note :

- (1) 600A compression lugs are made from aluminum.
- (2) 600A insulating plugs include an aluminum lug.
- (3) 900A compression lugs are made from copper.
- (4) 900A insulating plugs include a copper lug.

STEP2

Selection of Cable Insulation Dimension

Range Code	Inches	mm
A	0.640 - 0.760	16.3 - 19.3
B	0.720 - 0.845	18.3 - 21.5
C	0.785 - 0.970	19.9 - 24.6
D	0.910 - 1.065	23.1 - 27.1
E	0.980 - 1.140	24.9 - 29.0
F	1.080 - 1.280	27.4 - 32.5
G	1.220 - 1.420	31.0 - 36.1
H	1.360 - 1.560	34.5 - 39.6
J	1.480 - 1.700	37.6 - 43.2
K	1.640 - 1.840	41.7 - 46.7
L	1.780 - 1.965	45.2 - 49.9

ORDERING INFORMATION



Selection of Conductor Size (Al, Cu or Bi-Metal), add B in end of part number if a bi-metal lug is required. For example. 0002B; add C in end of part number if a Copper lug is required. For example. part number. 0002C; add Al in end of part number if a Aluminum lug is required. For example. 0002A. When selecting a shear bolt lug, use “shear bolt lug conductor code chart” and add SBC in the end of part number. For example, SBC-B-25-50/1-AL.

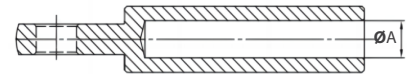

Conductor Code Table

CONDUCTOR CODE	Concentric or Compressed		Compactor Solid		Inner Diameter ØA(mm)
	AWG or kcmil	mm ²	AWG or kcmil	mm ²	Copper/Bi-metal/Aluminum Lug
0002	#2	35	#1	-	7.90
0001	#1	-	1/0	50	8.70
0010	1/0	50	2/0	70	10.02
0020	2/0	70	3/0	-	11.10
0030	3/0	-	4/0	95	12.40
0040	4/0	95	250	120	13.90
0250	250	120	300	150	15.00
0300	300	150	350	-	16.40
0350	350	-	400	185	17.90
0400	400	185	450/500	-	19.30
0450	450	-	500/550	240	20.10
0500	500	240	600	300	21.50
0550	550	-	650	-	22.60
0600	600	300	700	-	23.30
0650	650	-	750	400	24.10
0750	750	400	800	-	26.20
0800	800	-	900	-	27.10
0900	900	-	1000	500	28.70
1000	1000	500	-	-	30.20

Note :

Aluminum lug and Bi-metal lug for use on copper and aluminum conductors. Cooper lug for use on cooper conductors only.

ORDERING INFORMATION

Chardon Shear Bolt Lug

Example:

For a Shear Bolt Lug with a conductor range between 20-50 mm², the part number would be : SBC-B-25-50/1-AL.

Catalog No.	Conductor Range(mm ²)
SBC-B-25-50/1-AL	25-50
SBC-B-70-120/2-AL	70-120
SBC-B-150-240/2-AL	150-240
SBC-B-120-300/2-AL	120-300
SBC-B-300-400/3-AL	300-400



ORDERING EXAMPLE

An 15/25 kV Elbow, with a test point, and with copper lug required cable insulation dimension of 1.45 inch, and the compressed cable conductor size type is 550, the part number would be as follows:

15/25-TB	900T	H	0550C
----------	------	---	-------

If a shear bolt lug is selected in this kit, the part number would be as follows:

15/25-TB	900T	H	SBC-B-25-50/1-AL
----------	------	---	------------------

The part number includes the insulating plug, cap, and stud.

Note :

If you require a T-body installed with LRTP, a threaded lug is necessary for the installation. Please notify your local agent or Chardon of the need for this threaded lug.



ANHUI CHARDON ELECTRIC LTD.

No.808 Taiji Road Economic Develop Zone of Guangde County
Anhui China
Tel: 0563-2216688
Fax: 0563-2251806

CHARDON TAIWAN CORPORATION

No.37 Min-Chie Road, Tung Lo Industrial Park, Miao Li, Taiwan 366
Tel:+886-37-984385
Fax:+886-37-984770

SHANGHAI CHARDON ELECTRIC LTD.

Room 1202, office building No.399, Yun Gu Road, Jiading district,
Shanghai, China 201801
Tel: +86-21-39105900
Fax: +86-21-39105916

www.chardongroup.com·info@chardongroup.com