

42kV Cold Shrinkable Termination INSTALLATION For Three Core Cable

DESCRIPTION

The Chardon Cold Shrinkable Termination offers easy installation and reliable performance when terminating indoor and outdoor medium voltage cables. Made from high quality, UV resistant, silicone rubber, the Chardon Cold Shrinkable termination offers a combination of durability and high performance in the field.

The Chardon Cold Shrinkable Terminations include a stress controlling compound housing, preassembled on a plastic “hold out” tube. As the plastic hold out is removed, the stress-relief housing shrinks onto the cable. Chardon terminations are easy to install, and have a wide application range. No tools, or heat sources are required. The products are designed to last the entire life of the cable.

The Chardon Cold Shrinkable terminations are tested according to IEC 60502-4 standard .

ORDERING INSTRUCTIONS:

Standard Voltage Class	Part Number	Cable Insulation O.D. Range
42kV	T-42-CSTO -A	18.7 – 26.0
	T-42-CSTO -B	24.9 – 41.1
	T-42-CSTO -C	36.6 – 59.0

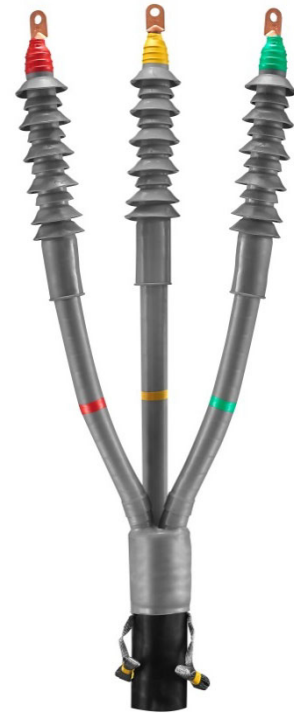

COLD SHRINKABLE TERMINATION KIT

CONTENT:

- - Cold Shrinkable Termination
- - Cold Shrinkable Jacket Seal Tube
- - Cold Shrinkable break out
- - Paper towel
- - Silicone lubricant
- - Sealing tape
- - Grounding Braid
- - Silicone tape
- - Copper tape
- - Filling tape
- - Constant-force spring
- - PVC tape
- - Sandpaper belt
- - Gloves
- - Installation & Operating instructions
- - Cable lug (Optional)
- - Triangle Cone

 **CAUTION:** All associated apparatus must be de-energized during installation and/or maintenance.

 **DANGER:** Do not touch or move energized product by hand. Failure to follow this instruction may result in serious or fatal injury, as well as damage to the product.

SAFETY INFORMATION

The instructions in this manual are not intended as a substitute for proper training or adequate experience in the safe operation of the equipment described. Only competent technicians, who are familiar with this equipment should install, operate and service it.

INSTALL PROCEDURE

STEP 1

- Fixed 3 core cable, remove the outer jacket A (The size of the A is Cold Shrinkable Jacket Seal Length +450mm) and prepare cable to armor 30mm and inside jacket 10mm. Use PVC tape to fixe Cu conductive shield of 3 phase cable.

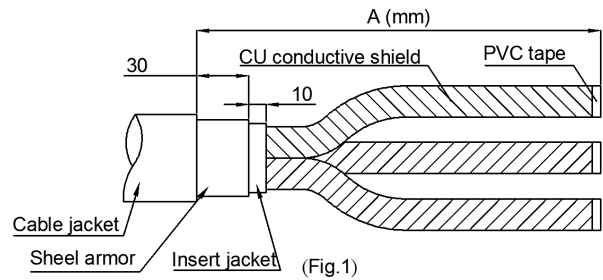

STEP 2

- Clean outer jacket and armor, and 15mm is evenly wrapped around a layer of sealing tape.
- Use constant-force spring to fix grounding braid into armor.
- Wrap sealing tape to cover constant-force spring and grounding braid on armor.

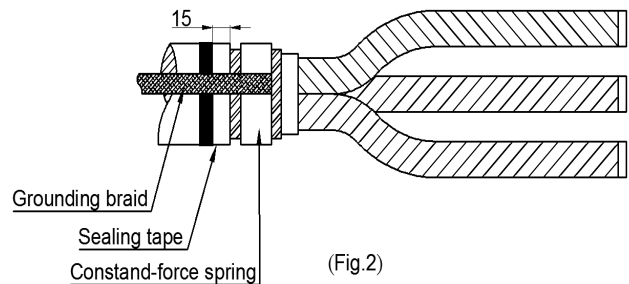

STEP 3

- The trigonometric cone inserts the bottom of the three core cable bifurcation.
- Wrap the other grounding braid in root of 3 phase cable and place on outer jacket. (Notice : the grounding braid should be placed different to first one).
- Use constant-force spring to fix second grounding braid or weld it on root of 3 phase cable. (Notice : the second grounding braid can not contact the first one.)

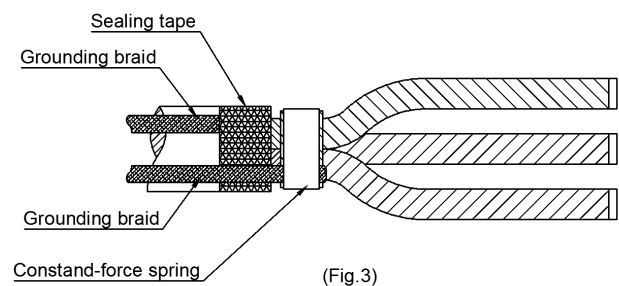

STEP 4

- The two grounding braid are placed on the sealing tape respectively.
- Wrap the filling tape onto the grounding braid and the copper shield.

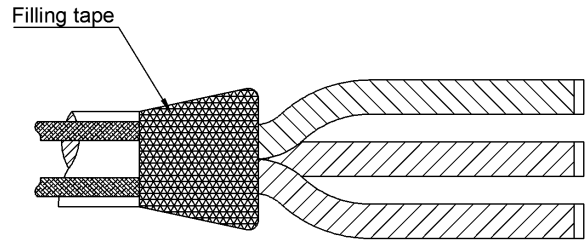

(Fig.4)

STEP 5

- Press the branching cone into the center of the three-core cable as far as possible to open the three cables
- Cover three finger cold shrink tube tight to root of 3 phase cable. Pull the hold out tubes at the anti-clockwise.
- Cover cold shrinkable tube tight to the end of 20-30mm from break out.
- Remove hold out tube, check cold shrink tube shrink completely.

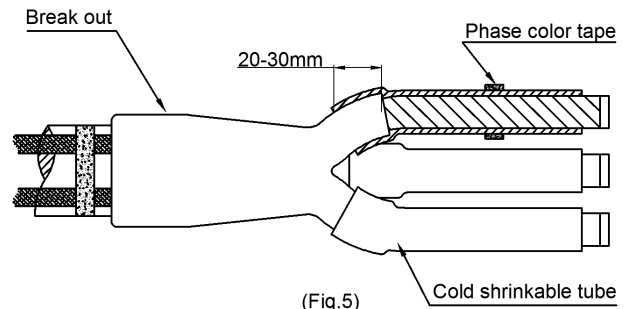

A. Prepare Cable

STEP 6

- Prepare cable using dimensions as shown.
- Check the size of the cable top to the cold tube port. If less than the diagram size as show, peel off the excess cold shrink tube.

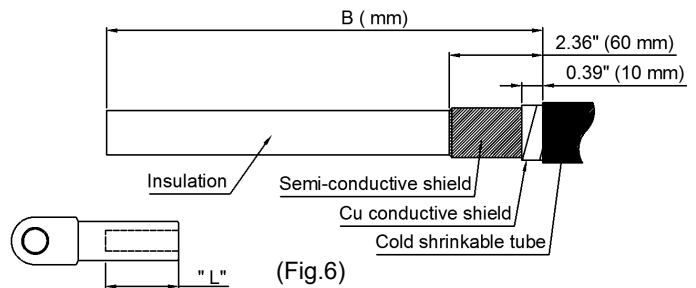

NOTE: Ensure that all parts of the cable are not damaged. If there is any irreparable damage, a new cable needs to be made .If there is any impurity or slight damage on the surface of the insulation , it can be polished with fine sandpaper.

Part Number	42-A	42-B	42-C
Cable Insulation O.D. Range	18.7 – 26.0	24.9 – 41.1	36.6 – 59.0
B (mm)	520+L	530+L	535+L
"L" refers to the hole depth of the connector			

STEP 7

- Sand off the sharp corners of the Cu conductive shield with coarse sandpaper.
- Fix the Cu conductive shield with copper tape as shown.

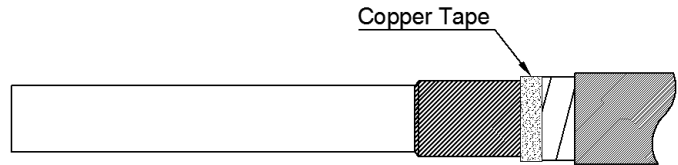

(Fig.7)

B. Install Termination

STEP 8

- Polish and clean thoroughly the insulation by using sandpaper belt and paper towel then apply the silicone lubricant around the dotted line area.

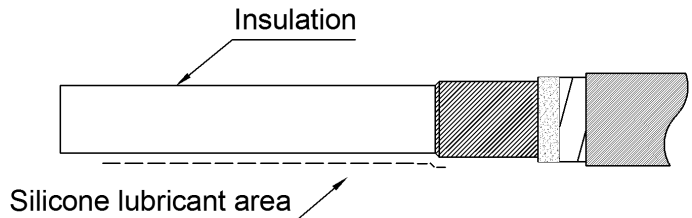

(Fig.8)

STEP 9

- Place the cold shrink termination onto the cable, aligning the install positioning line with the end of the hold out tube. Take out the hold out tube to complete the installation.

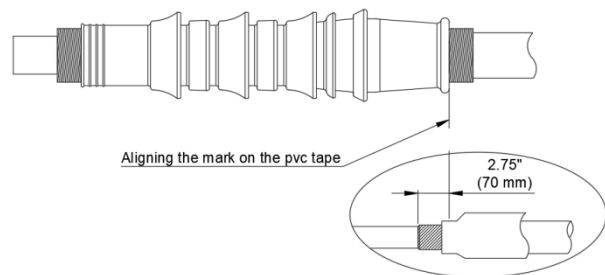

(Fig.9)

STEP 10

- The installation is completed, as shown in Figure 10.
- Check the installation, if there is any deviation or skew, Adjust immediately.

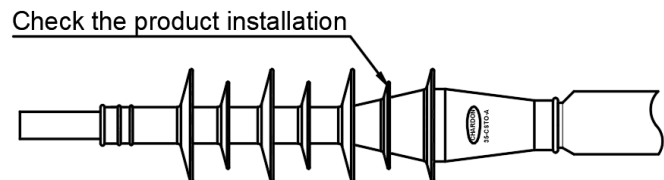

(Fig.10)

C. Install Compression Connect

STEP 11

- Keep the "L+0.39"(10mm)" insulation and remove the excess part.
- Remove the insulation to expose the bare conductor according to lug depth "L" as shown in Fig.11.

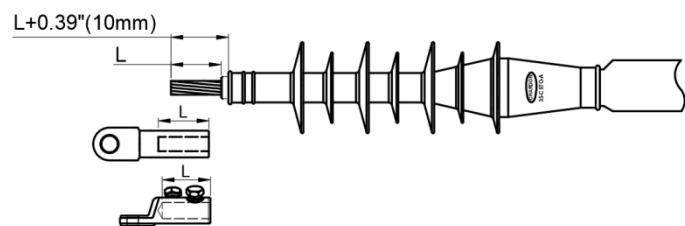

(Fig.11)

STEP 12

- Clean the exposed conductor by using a wire brush.
- Place the connector on the exposed conductor and Install it.

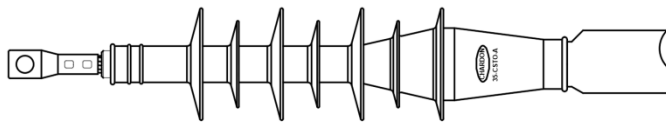

(Fig.12)

STEP 13

- Wrap the sealing tape between the insulation and connector.

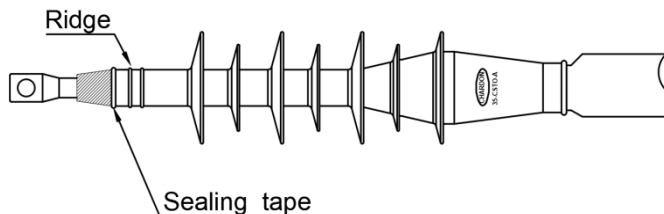

(Fig.13)

STEP 14

- Seal the top of the terminator at the connector area with Silicone tape.

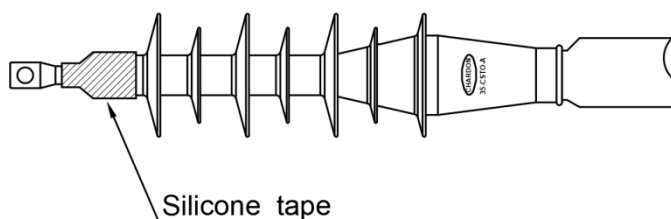

(Fig.14)

In as much as CHARDON GROUP, Inc. has no control over the use which others may put the material, it does not guarantee that the same results as those described herein will be obtained, Each user of the material should make his own tests to determine the material's suitability for his own particular use. Statements concerning possible uses of the materials described herein are not to be construed as constituting a license under any CHARDON GROUP, inc. patent covering such use or as recommendations for use of such materials in the infringement of any patent.

FOR FURTHER INFORMATION WRITE TO



sales@chardongroup.com