

15 / 25 / 35 kV 200A LOADBREAK FEED-THRU INSERT INSTALLATION & OPERATING INSTRUCTIONS

DESCRIPTION:

The CHARDON Loadbreak Feed-Thru Insert is designed for assembly to a high-voltage bushing well and is used as a mating loadbreak connector. The torque limiting ratchet feature allows the lineman to rotate the feed-thru insert 360° to locate it in the best position for the specific application. The bail assembly supplied with the kit can be used to prevent the insert from moving. The Feed-Thru insert is designed to operate with a bushing well meeting the interface requirements of Fig. 3 of ANSI/IEEE 386. The Elbow interface of the Feed-Thru Insert meets the requirements of ANSI/IEEE 386 as defined below:

- Class 15kV 200A (8.3kV and 8.3/14.4kV)
- Class 25kV 200A (15.2kV and 15.2/26.3kV)
- Class 35kV 200A (21.1kV and 21.1/36.6kV)

KIT CONTENT:

- | | |
|--|--|
| <ul style="list-style-type: none"> ● Feed-Thru Insert with Shipping Caps (Not insulating) ● Fixed Plate ● J-bolt hail hooks & Wing Nuts | <ul style="list-style-type: none"> ● Silicone Grease (5g) ● Paper Towel ● Instruction Sheet |
|--|--|



CAUTION:

- The installation of Chardon products must be carried out by qualified technical personnel.
- Contact with energized equipment can cause serious damage and even death.
- Wear appropriate protective equipment.
- Make sure Chardon Accessories are completely dry and in good condition at the time of installation.



DANGER:

- Do not touch or handle energized products without adequate protective equipment. Errors in the compliance of this instruction can result in damage to the product, serious injuries to people and even death.
- All associated equipment must be de-energized during installation and maintenance.
- The following instructions do not cover details or variables in the change / installation of the product, to prevent contingencies, please contact the team of Chardon technicians if required.

SAFETY INFORMATION

The instructions in this manual are not intended as a substitute for proper training or adequate experience in the safe operation of the equipment described. Only competent technicians, who are familiar with this equipment should install, operate and service it.

Warranty

Chardon products are guaranteed for a period of 2 years after their date of purchase, to make this guarantee effective you can come only by presenting a purchase invoice to your authorized Chardon distributor. The warranty will not be valid in the following cases:

1. When the product has been used under conditions other than normal.
2. When the product has not been operated according to the instructions for use.
3. When the product has been altered or repaired by persons not authorized by Chardon.
4. When using components that are not compatible with Chardon accessories.

Inasmuch as CHARDON GROUP, Inc. has no control over the use which others may put the material, it does not guarantee that the same results as those described herein will be obtained, each user of the material should make his own tests to determine the material's suitability for his own particular use. Statements concerning possible uses of the materials described herein are not to be construed as constituting a license under any CHARDON GROUP, inc. patent covering such use or as recommendations for use of such materials in the infringement of any patent.

FOR MORE INFORMATION, PLEASE CONTACT YOUR LOCAL DEALER.

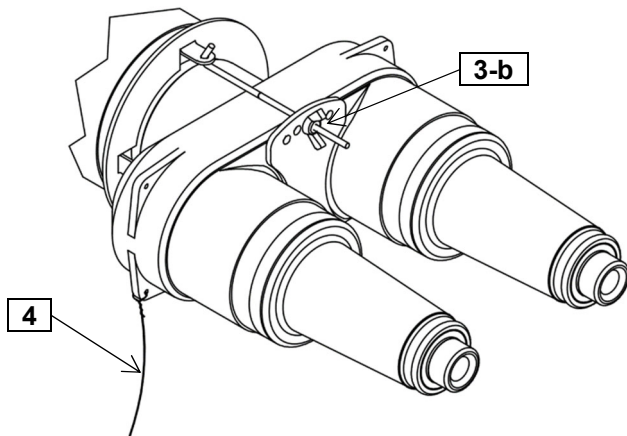
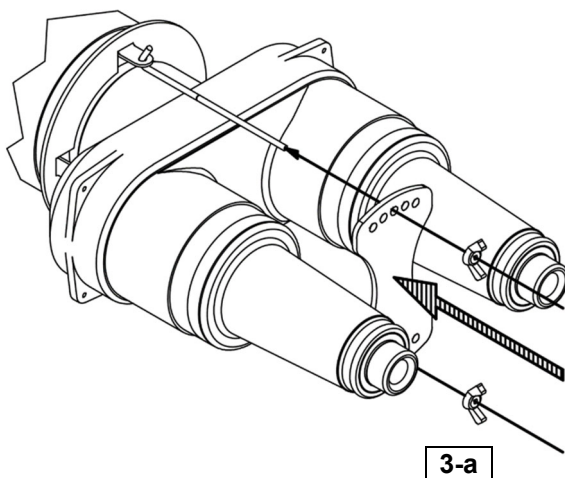
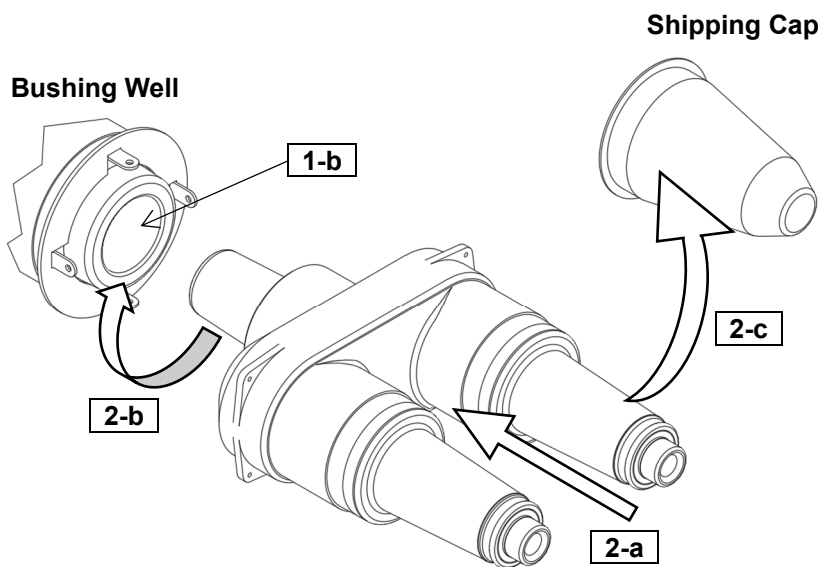

STEP 1:

- Remove the protective cover from the high-voltage bushing well.
- Clean bushing well and apply a thin uniform coating of lubricant provided to the bushing insert interface as shown.

STEP 2:

- Place base of Feed-Thru Insert into lubricated bushing well. Turn Feed-Thru Insert clockwise onto bushing well stud. An audible "clicking" sound indicates the Feed-Thru Insert is fully seated.
- Continue clockwise rotation to position the feed-thru insert as desired.
- Remove the shipping cap from Feed-Thru Insert.

STEP 3:

- Assemble the fixed plate by inserting the threaded portion of the J-bolt bail hooks through the center set of holes of the stainless steel fixed plate and attach the wing nuts to hold them in place.
- Tighten the wing nuts until snug.

STEP 4:

- Attach #14 AWG copper ground wire to the Rotatable Feed-Thru Insert grounding tab.
- Connect ground wire to system ground.

STEP 5:

- Replace the shipping cap after cleaning the operating interface.
- If you need to install a matching product, refer to the installation instructions of the supporting product for the next step.

NOTE:
 DO NOT SUBSTITUTE OTHER LUBRICANTS FOR THOSE PROVIDED.

WARNING:
 THE SHIPPING CAP IS NOT SUITABLE AS AN INSULATING CAP FOR ENERGIZED USE.

WARNING:
 ALL ASSOCIATED APPARATUS MUST BE DE-ENERGIZED BEFORE PREPARATION OR REPREPARATION PROCEDURES.

LOADBREAK OPERATION

- Securely fasten a suitable live-line tool to the pulling eye of the mating loadbreak elbow.
- Without exerting any pulling force, slightly rotate the elbow clockwise to break surface friction between the elbow and bushing.
- Withdraw the elbow from the bushing with a fast, firm, straight motion, being careful not to place the connector near a ground plane.
- Place the elbow on an appropriate accessory device, following the operating instructions for that accessory.
- Place an insulated protective cap with drain wire attached to system ground on any exposed energized bushing using a suitable live-line tool.

LOADMAKE OPERATION

- Area must be clear of obstructions or contaminants that would interfere with the operation of the loadbreak elbow.
- Securely fasten a suitable live-line tool to the pulling eye.
- Place the loadbreak elbow over the bushing, inserting the white arc follower of the probe into the bushing approximately 2 1/2" until a slight resistance is felt.
- Immediately thrust the elbow onto the bushing with a fast, firm, straight motion, with sufficient force to latch the elbow to the bushing.
- Push again on the elbow with the live-line tool, and then pull gently to make sure that it is secure.