

**IEC Separable Connectors  
36/102kV Coupling (Rear)  
T-Body Surge Arrester**



## APPLICATION

The Chardon T-Body Surge Arrester is an arrester combined within a coupling (rear) T-Body interface. It is designed to protect

apparatus, including transformers, switchgear, and other equipment from high voltage surges due to lightning or switching.

## KEY FEATURES

- Provides fully shielded deadfront arrester protection.
- Metal (zinc) Oxide Varistor (MOV) gapless design.
- EPDM insulation rubber molded around MOV module.
- Mounting can be vertical, horizontal, or any angle in between.
- No minimum phase clearance requirements.
- 100% electrical tested at factory.

## PRODUCT RATINGS

36-RDTA102	
Rated Voltage Class (Ur)	36 kV
Nominal Discharge Current of Arrester	10 kA
Residual Voltage of Nominal Discharge Current	<102 kV
Maximum Continuous Operating Voltage	28.8 kV
Voltage of DC 1mA Current	≥51.6 kV

## PRODUCTION TESTS

Tests conducted in accordance with IEC 60099-4.

- Partial Discharge – 30.24kV<3pC
- Voltage of DC 1mA Current – ≥ 51.6 kV

Tests conducted in accordance with Chardon manufacturing process requirements:

- Physical Inspection
- Periodic Dissection
- Periodic X-ray Analysis

• 36-RDTA102-03012023-REV01

## DETAILED COMPOSITION OF THE CHARDON 36 KV/102KV COUPLING (REAR) T-BODY SURGE ARRESTER

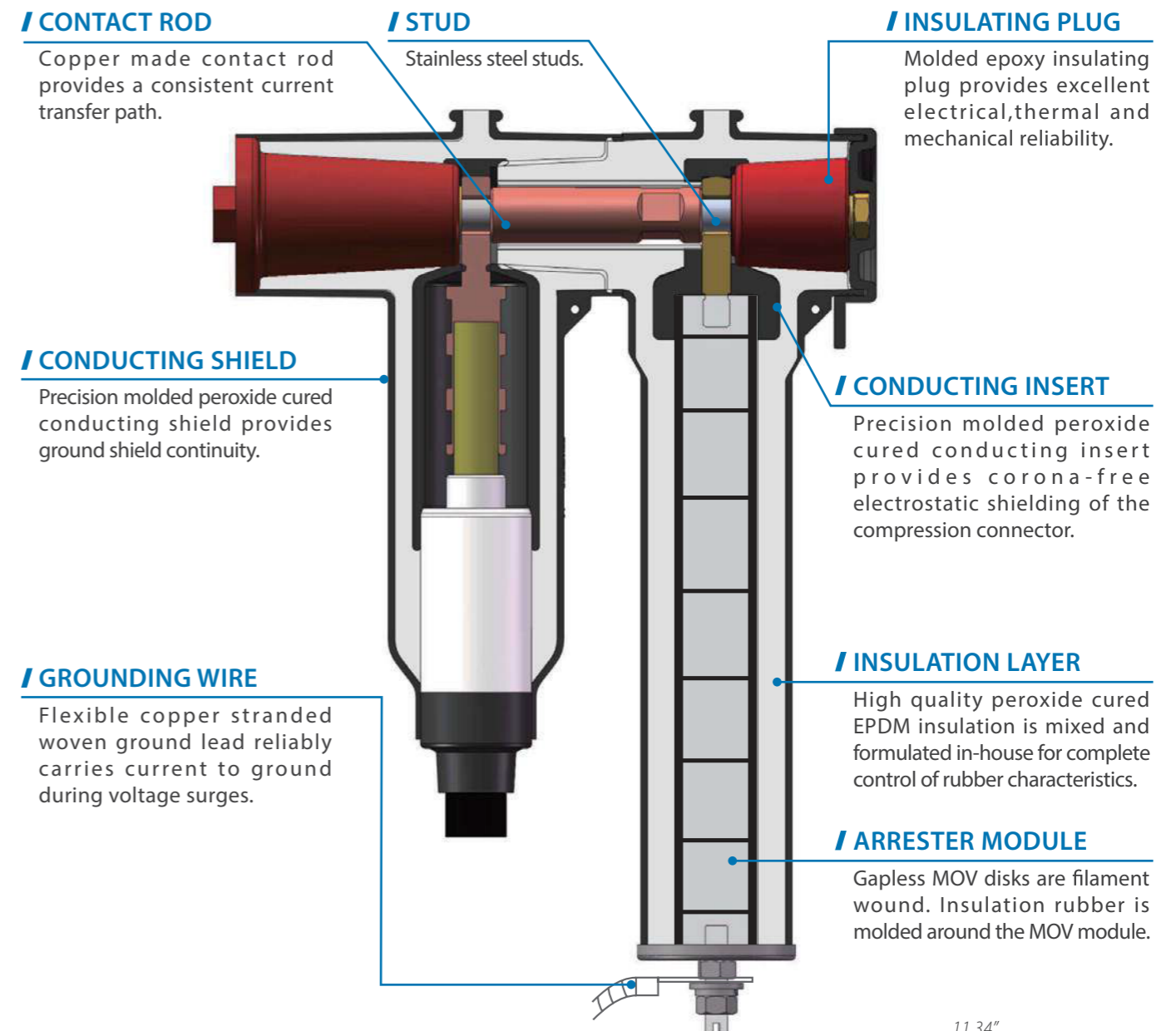

## ORDERING INFORMATION

IEC 36/102 kV 10kA Rear T-body Surge Arrester	36-RDTA102-10
---	---------------

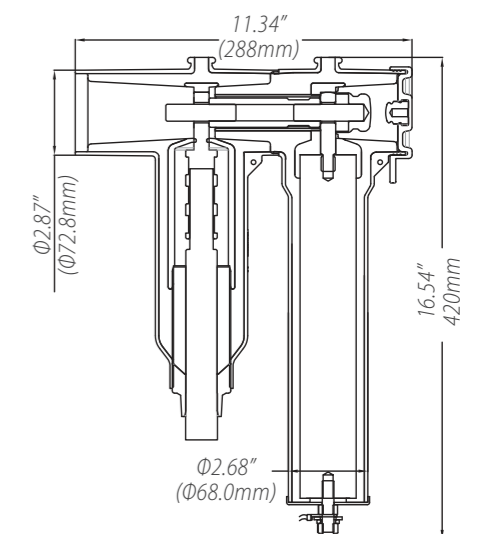



**CHARDON TAIWAN CORPORATION**

No.37 Min-Chie Road, Tung Lo  
Industrial Park, Miao Li, Taiwan 366

Tel : +886-37-984385

Fax : +886-37-984770

[www.chardongroup.com](http://www.chardongroup.com) • [info@chardongroup.com](mailto:info@chardongroup.com)