

Polymer Recloser for Automation of Overhead Lines

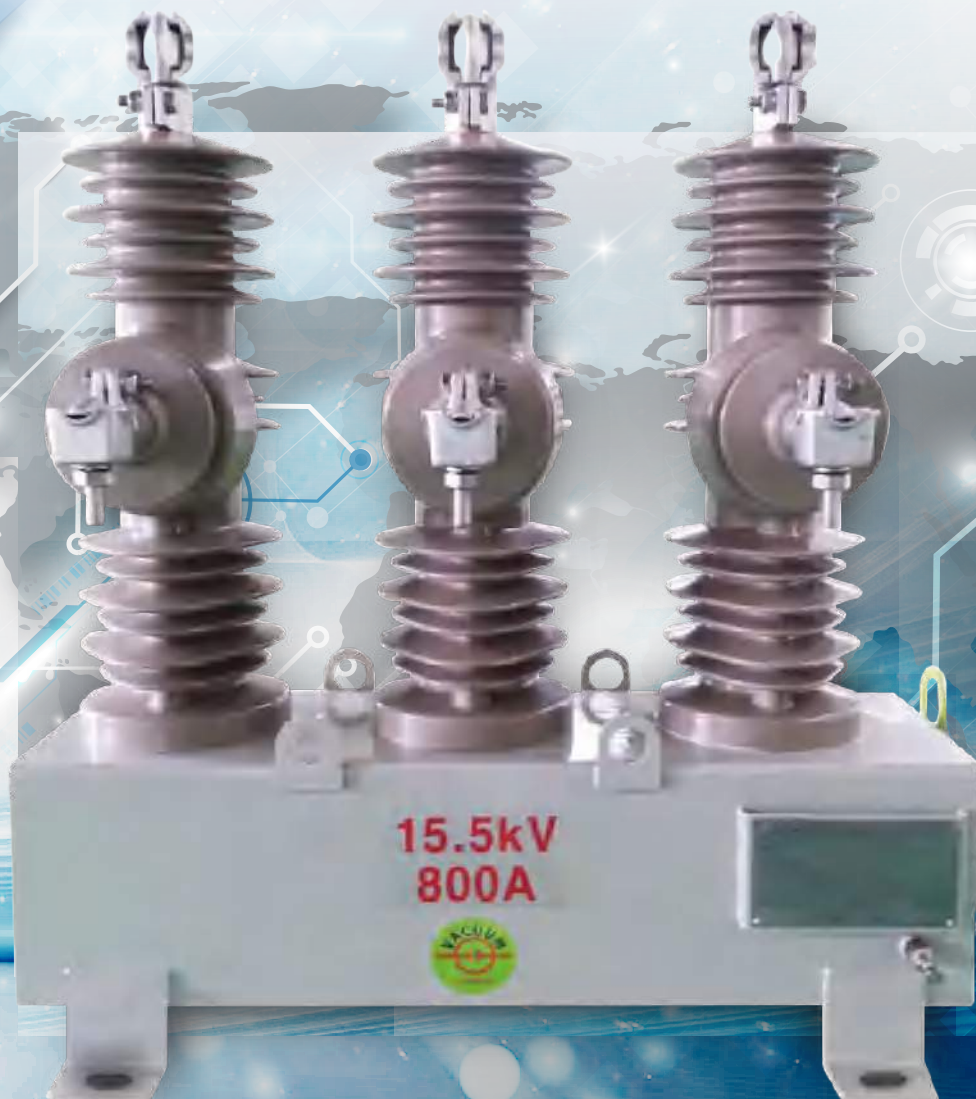

RATINGS

Model	-	CKMR -15	CKMR-27	CKMR-38
Maximum System Voltage	kV	15.5	27	38
Rated Current	A	800	800	800
Rated Frequency	Hz	50/60	50/60	50/60
Life of Mechanical Operation	C-O	≥10,000	≥10,000	≥10,000
Pollution Level (SPS class)	a/b/c/d/e	e, very heavy	e, very heavy	e, very heavy
Breaking Capacity				
Rated Symmetrical Interrupting Current	kA	16	16	16
Making Current (peak)	kA	40/41.6	40/41.6	40/41.6
Cable Charging Current	A	10	25	40
Line Charging Current	A	2	5	5
Impulse Basic Insulation Level (1.2 x 50us)				
Phase to Earth	kV BIL	110	150	170
Across Interrupter	kV BIL	110	150	170
Power Frequency Insulation Level				
Phase to Earth	kV	50	60	70
Across Interrupter	kV	50	60	70
Operation Control Power	V	120 or 220Vac		
	V	24Vdc		
Ambient Temperature	°C	-30 ~ +70		

KEY FEATURES

- ✓ Polymer insulation – environmentally friendly product.
- ✓ Magnetic Actuator Mechanism, Vacuum Interrupter.
- ✓ Maintenance free during its entire lifetime / long mechanical and interrupting life.
- ✓ Compact design and outdoor-use friendly.
- ✓ Six voltage sensors – three source and three load.
- ✓ Phase fault, Ground fault, SEF & Under/Over Frequency, Under/Over Voltage.
- ✓ Cold load pickup, Inrush restraints, Phase sync. Check, Hot line tag.
- ✓ 58 TC curves (IEC, ANSI, Recloser-Innate, User defined curves).
- ✓ DNP 3.0 Protocol SCADA System.

EPOXY DIELECTRIC GREEN RECLOSER

Insulation Material

- ✓ Hydrophobic cycloaliphatic Epoxy resin.
- ✓ Light weight & compact design for easy handling and installation.
- ✓ Improved performance in heavily polluted areas.
- ✓ Increased weather durability and improved aging.

Integrated sensors

- ✓ 3 numbers of Imbedded Current Transformer.
- ✓ 6 numbers of Imbedded Capacitive Voltage Divider.

Mechanism

- ✓ Magnetic gang operation.
- ✓ Simple design.
- ✓ No power required to hold contacts in closed.
- ✓ Direct force applied (no linkage between Magnetic Actuator and Vacuum Interrupter).
- ✓ 15 opening and closing operations with secondary power supply.

Vacuum Interrupter

- ✓ High interrupting capacity.
- ✓ Very compact design.
- ✓ Low chopping current, limiting inductive switching overvoltage to safe values.
- ✓ Features an axial magnetic field that minimizes contact erosion and ensures a long service life.

FTU200

PROTECTION

- ✓ Fault Detection
 - Definite Time Protection / High Current Trip / Single shot Operation.
 - Time - Current curve (IEC, ANSI/IEEE Standard curves, User curves)
- ✓ Cold Load Pickup
- ✓ Sensitive Earth Fault Detection
- ✓ Directional (Bi-directional)
- ✓ Inrush Restraints
- ✓ Open line detection (Loss of phase)
- ✓ Phase sync check
- ✓ Under/Over Voltage
- ✓ Under/Over Frequency
- ✓ Auto Reclosing Sequence
 - 1st: 0.5-180 / 2nd: 1-180 / 3rd: 1-180, Reset time : 3-180 (Unit – second)
- ✓ Dead Time (0.5 -180 seconds)
- ✓ Multiple Protection Groups

CONTROL CABINET

MEASUREMENT

- Voltage, Current, Active power, Reactive power, Power factor, Frequency, Energy, Harmonic, Demand Current and Power.

COMMUNICATION PORT

- RS232C, RS485, Ethernet/Fiber Optic, GSM(SMS)
- USB port or RS232 port for maintenance.

RECORDING

- Event recording.
 - I/O(1023 events), Function(1023), System(255), Fault(255), PQM(255), Demand I, P, Q Events(1023), Max. I,P,Q Event(1023).
- Waveform event recording.
 - 128 samples, 20 cycles (64 samples/40 cycles, 32 samples/80cycles, 16 samples/160cycles)
- COMTRADE file format rule

COUNTER

- FTU restarting time.
- Switch trip, Fault detection, PQM, THD.

SOFTWARE FTUMan

- New interface presentation for configuration & settings.
- Event & Waveform load.
- Measurement & Status display.
- Waveform File upload and convert.
- SCADA monitors protocol data frame between devices.

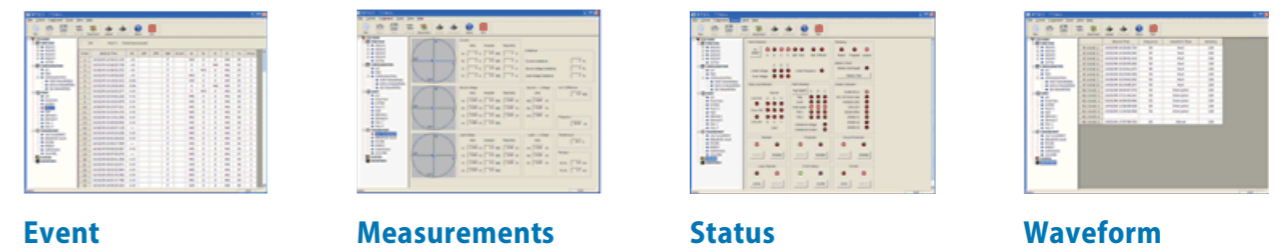
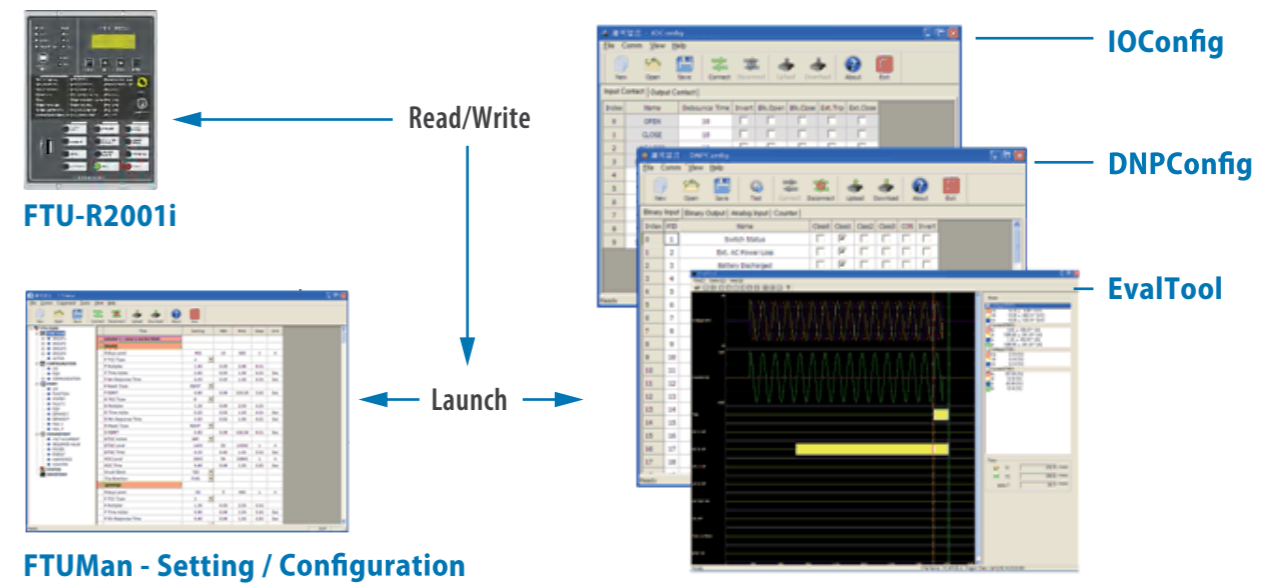

TANK

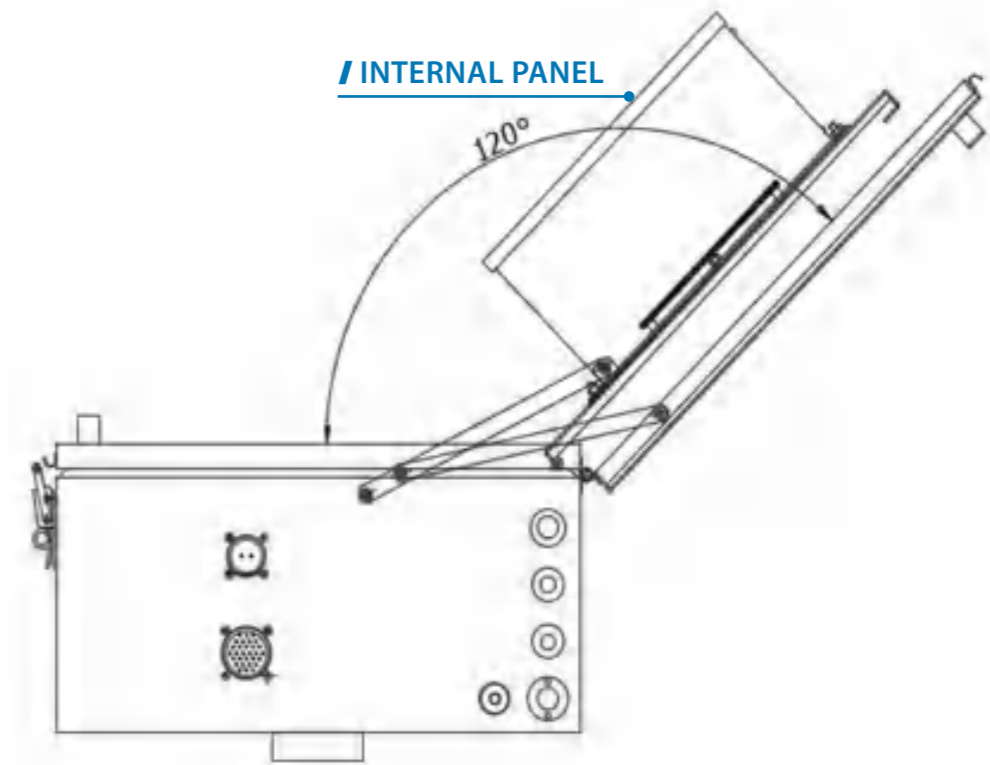
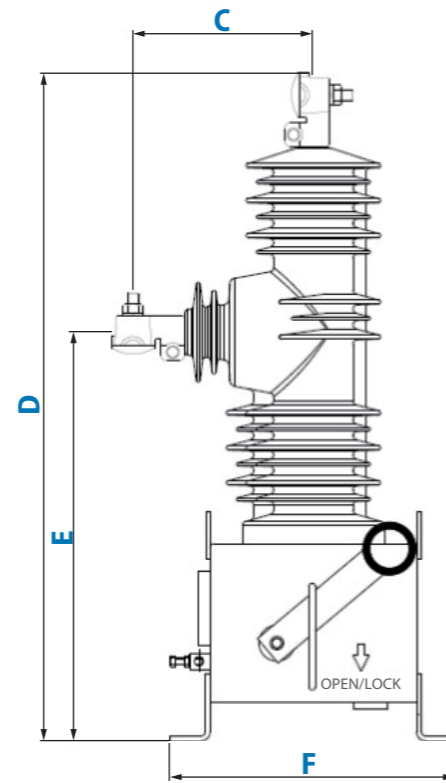
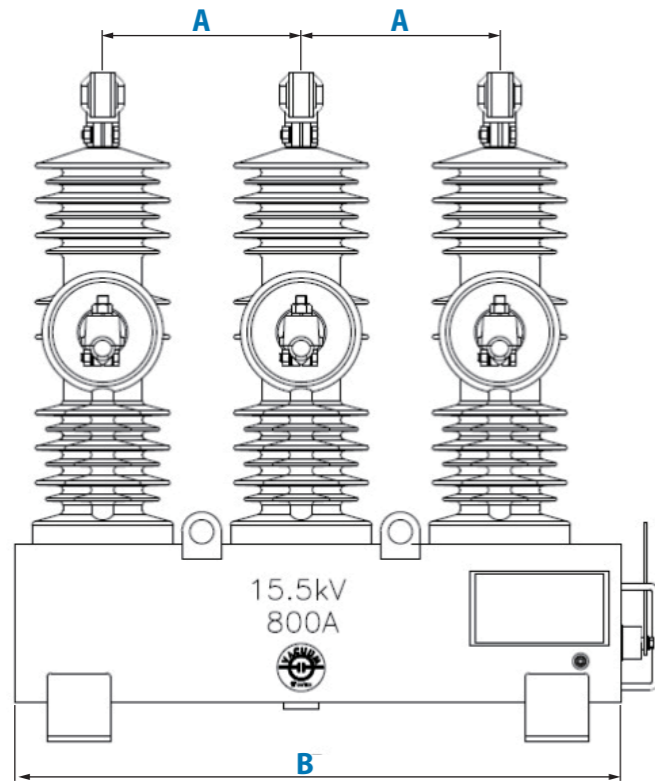

	A	B	C	D	E	F
15.5KV	250	762	227	840	514	370
27KV	320	842	253	910	561	370
38KV	340	942	370	1080	683	390

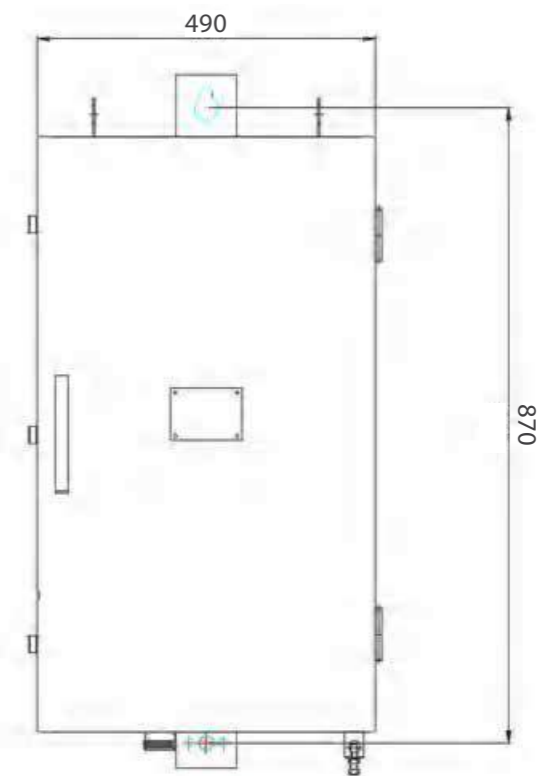



CHARDON KOREA CORPORATION

191-28, Gajang-ro, Jeongnam-myeon, Hwaseong-si,
Gyeonggi-do, 445-962, SOUTH KOREA

www.chardongroup.com • info@chardongroup.com