

# Chardon 15kV and 25kV Elbow Arresters



## APPLICATION

The Chardon Elbow Arrester combines metal oxide varistor module in a rubber elbow to provide overvoltage protection for 200A interface systems. The Chardon Elbow Arrester housing design meets the IEEE 386 standard. It is molded with high quality peroxide-cured insulating and semi-conducting rubber and is fully interchangeable with competitors' products that also meet IEEE standard 386. Chardon Elbow Arresters are used on

underground systems in pad-mounted transformer and entry cabinets, vaults switching devices and other insulation to provide shielded deadfront arrester protection. Installing Chardon Elbow Arrester at both ends of an open point on a loop system and the end of a radial system protect equipment and extend cable life.

## PRODUCTION TEST OF ELBOW ARRESTER

- / Partial Discharge Test
- / Voltage at 1mA
- / Leakage Current
- / Physical Inspection
- / Periodic Dissection
- / Periodic X-ray Analysis

## PRODUCTION TEST OF MOV MODULE

- / Partial Discharge Test
- / Voltage at 1mA
- / Leakage Current
- / Batch High-current, Short-duration test
- / Batch Thermal Stability test
- / Batch Aging test
- / Physical Inspection

• 15/25LEA-20200608-REV02

## DETAILED COMPOSITION OF THE CHARDON ELBOW ARRESTERS

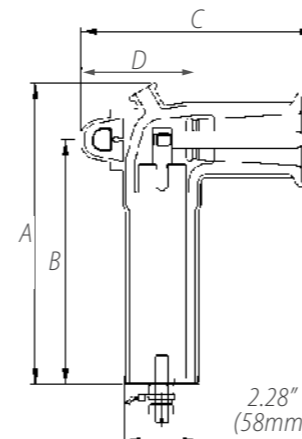
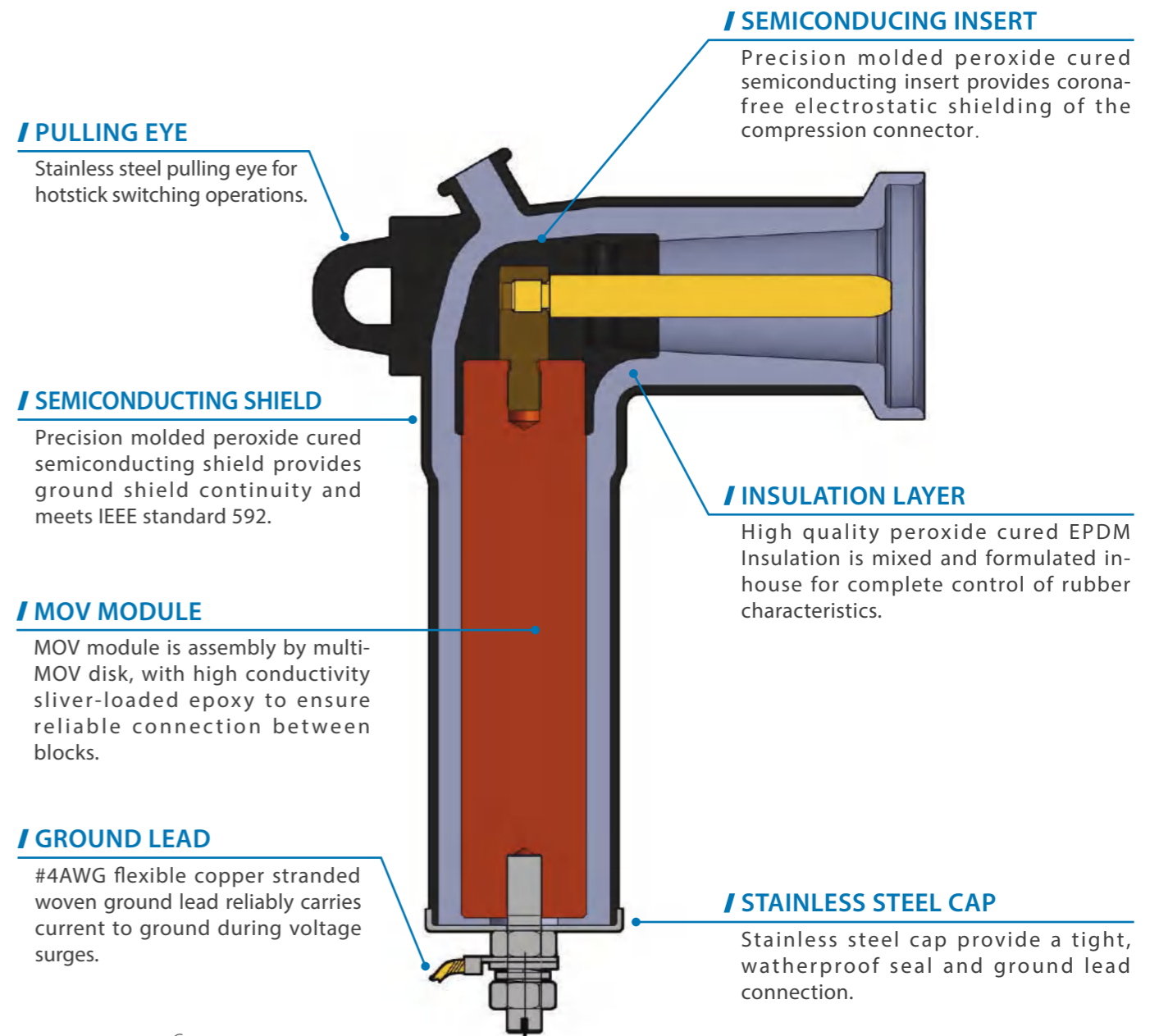

Voltage Class	15kV	25kV
A	232mm	232mm
B	189mm	189mm
C	181mm	195mm
D	88mm	100mm

**Table 1**

Electrical Characteristics							
Duty Cycle Voltage Rating (kV)	MCOV (kV)	Equivalent Front-of-wave (kV crest)	Maximum Discharge Voltage (kV crest) 8/20 μs Current Wave				
			1.5kA	3kA	5kA	10kA	20kA
3	2.55	9.8	7.7	8.0	8.5	9.5	10.6
6	5.1	19.6	15.4	16.0	17.0	18.9	21.3
9	7.65	29.3	22.5	23.5	25.5	28.4	31.9
10	8.4	32.7	24.9	26.0	28.0	31.1	35.0
12	10.2	39.1	30.2	31.5	34.0	37.8	42.5
15	12.7	48.9	38.4	40.0	42.5	47.3	53.1
18	15.3	58.7	46.0	48.0	51.0	56.7	63.8
21	17.0	68.4	53.6	56.0	59.5	66.0	74.0

**Table 2**

System Voltage (kV rms)		Commonly Applied Arrester Duty-cycle(MCOV) Voltage Rating (kV rms) on Distribution System		
Nominal Voltage	Maximum Voltage Range B	4-Wire Multigrounded Neutral Wye	3-Wire Low Impedance Grounded	Delta and 3-wire High Impedance Grounded
2.4	2.54	-	-	3(2.55)
4.16 Y/2.40	4.40 Y/2.54	3(2.55)	6(5.1)	6(5.1)
4.26	4.40	-	-	6(5.1)
4.80	5.08	-	-	6(5.1)
6.90	7.26	-	-	9(7.65)
8.32 Y/4.80	8.80 Y/5.08	6(5.1)	9(7.65)	-
12.00 Y/6.93	12.7 Y/7.33	9(7.65)	12(10.2)	-
12.47 Y/7.20	13.20 Y/7.62	9(7.65) or 10(8.4)	15 (12.7)	-
13.20 Y/7.62	13.97 Y/8.07	10(8.4)	15 (12.7)	-
13.80 Y/7.97	14.52 Y/8.388	10(8.4) and 12(10.2)	15 (12.7)	-
13.80	14.52	-	-	18(15.3)
20.76 Y/12.00	22.00 Y/12.70	15 (12.7)	-	--
22.86 Y/12.00	22.00 Y/12.70	15 (12.7)	-	-
24.94 Y/14.40	26.40 Y/15.24	18 (15.3)	-	-
27.60 Y/15.935	29.255 Y/16.89	21 (17.0)	-	-

**PROTECTIVE CHARACTERISTICS**

The protective characteristics of the elbow arrester are shown in Table 1.

**GENERAL APPLICATION RECOMMENDATION**

The rating of an arrester is the maximum power frequency line-to-ground voltage at which the arrester is designed to pass an operating duty-cycle test. Table 2 provides a general application guide for the selection of the proper arrester rating for a given system voltage and system grounding configuration as outlined in the IEEE Std C62.22 standard application guide.

To ensure that the arrester ratings will not be exceeded, CHARDON GROUP application engineers are available to make recommendations.

**PERFORMANCE TEST CHARACTERISTICS**

The Elbow Arrester consistently withstands the following design test:

- / Duty Cycle Test
- / High-current, Short-duration Discharge test
- / Low-Current, Long-Duration Discharge test

**ORDERING INFORMATION**

IEEE Std 386 Standard Interface	Duty Cycle (kV)	MCOV Rating (kV)	Catalog Number
<b>15kV</b>	3 kV	2.55 kV	15-LEA3
	10 kV	8.4 kV	15-LEA10
	12 kV	10.2 kV	15-LEA12
	15 kV	12.7 kV	15-LEA15
	18 kV	15.3 kV	15-LEA18
	21 kV	17.0 kV	15-LEA21
<b>25kV</b>	10 kV	8.4 kV	25-LEA10
	12 kV	10.2 kV	25-LEA12
	18 kV	15.3 kV	25-LEA18
	21 kV	17.0 kV	25-LEA21



**CHARDON TAIWAN CORPORATION**

No.37 Min-Chie Road, Tung Lo  
Industrial Park, Miao Li, Taiwan 366

Tel : +886-37-984385

Fax : +886-37-984770

[www.chardongroup.com](http://www.chardongroup.com) • [info@chardongroup.com](mailto:info@chardongroup.com)