

250A, 24kV Class Interface A1 Equipment Bushing



APPLICATION

The Chardon 24kV Interface A1 equipment bushing meets the full requirement of EN 50180, EN 50181&IEC 60137, provides a sliding interface made of quality epoxy. The

part is used in equipment insulated with oil fluid, such as transformers, switchgears and capacitors. It equipped with 6 tabs for the bail restraint.

PRODUCTION TESTS

Tests conducted in accordance with IEC 60137

- / Minimum Corona Voltage Level - 20.8 kV
- / AC 5 Minute Withstand - 55 kV

Tests conducted in accordance with Chardon manufacturing process requirements:

- / Physical Inspection
- / Periodic Dissection
- / Periodic X-ray Analysis

VOLTAGE RATINGS

Voltage Class (U_m)	24 kV
AC 5 Minute Withstand	55 kV
BIL and Full Wave Crest	125 kV
Minimum Corona Voltage Level	20.8 kV < 10 pC

CURRENT RATINGS

Continuous Current	250 A
---------------------------	-------

ORDERING INFORMATION

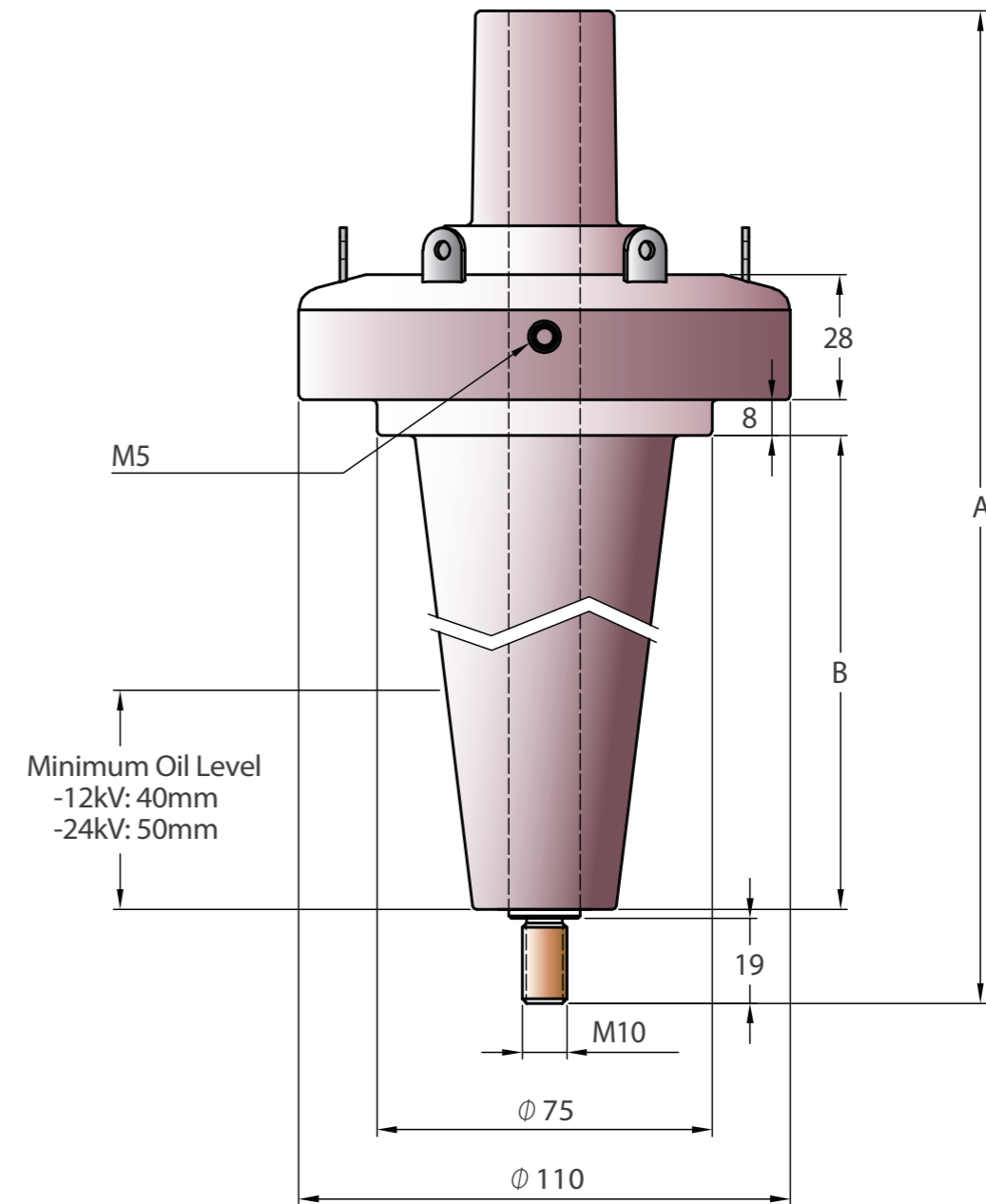

Chardon Part Number	Dimensions	
	A	B
24-DIB250-1-I	284	168
24-DIB250-2-I	222	106
24-DIB250-3-I	171	55

ORDERING INFORMATION

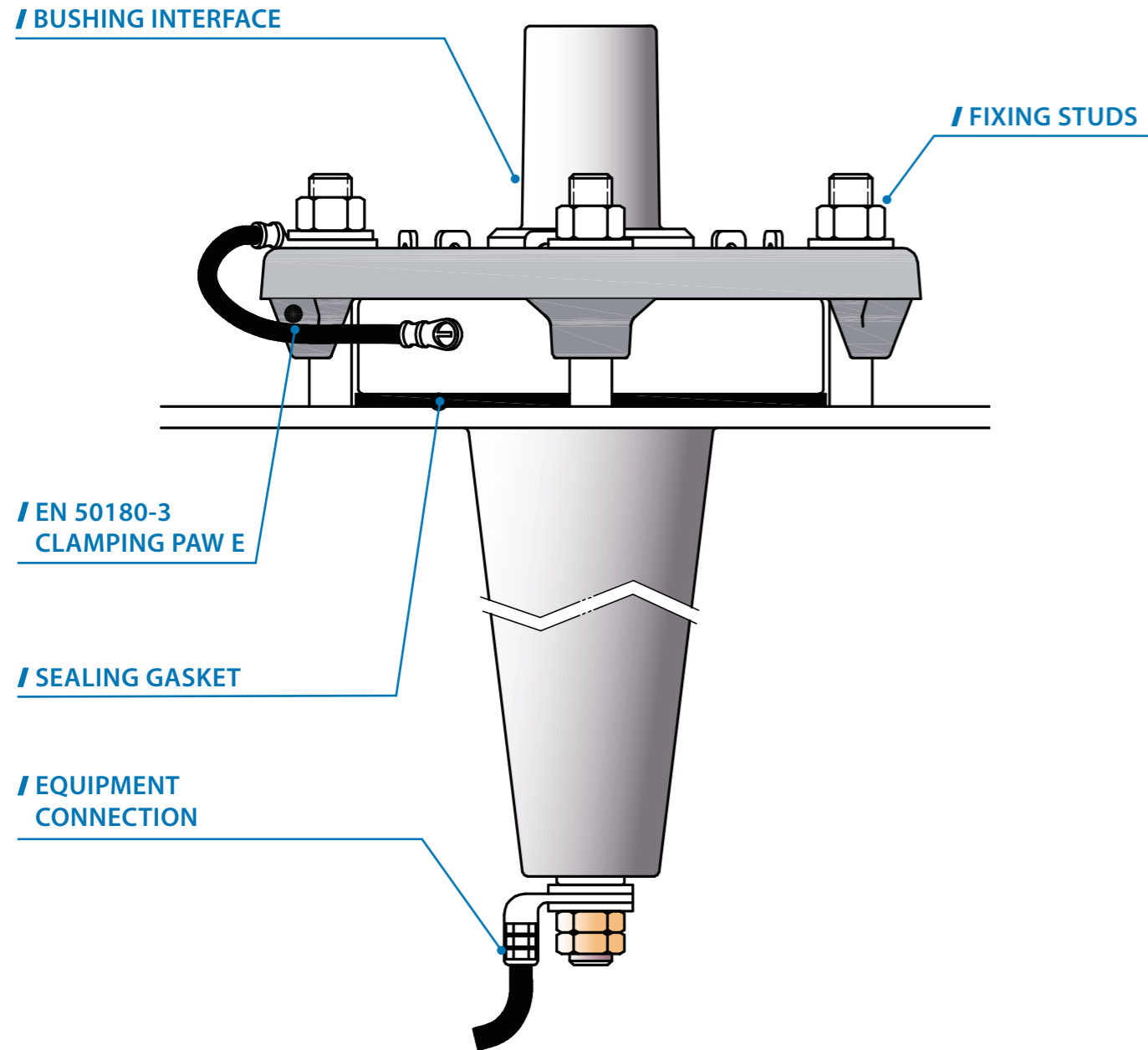

Fixings For Interface A1 Equipment Bushings EN 50180-3 & DIN 42 538

ORDERING INFORMATION

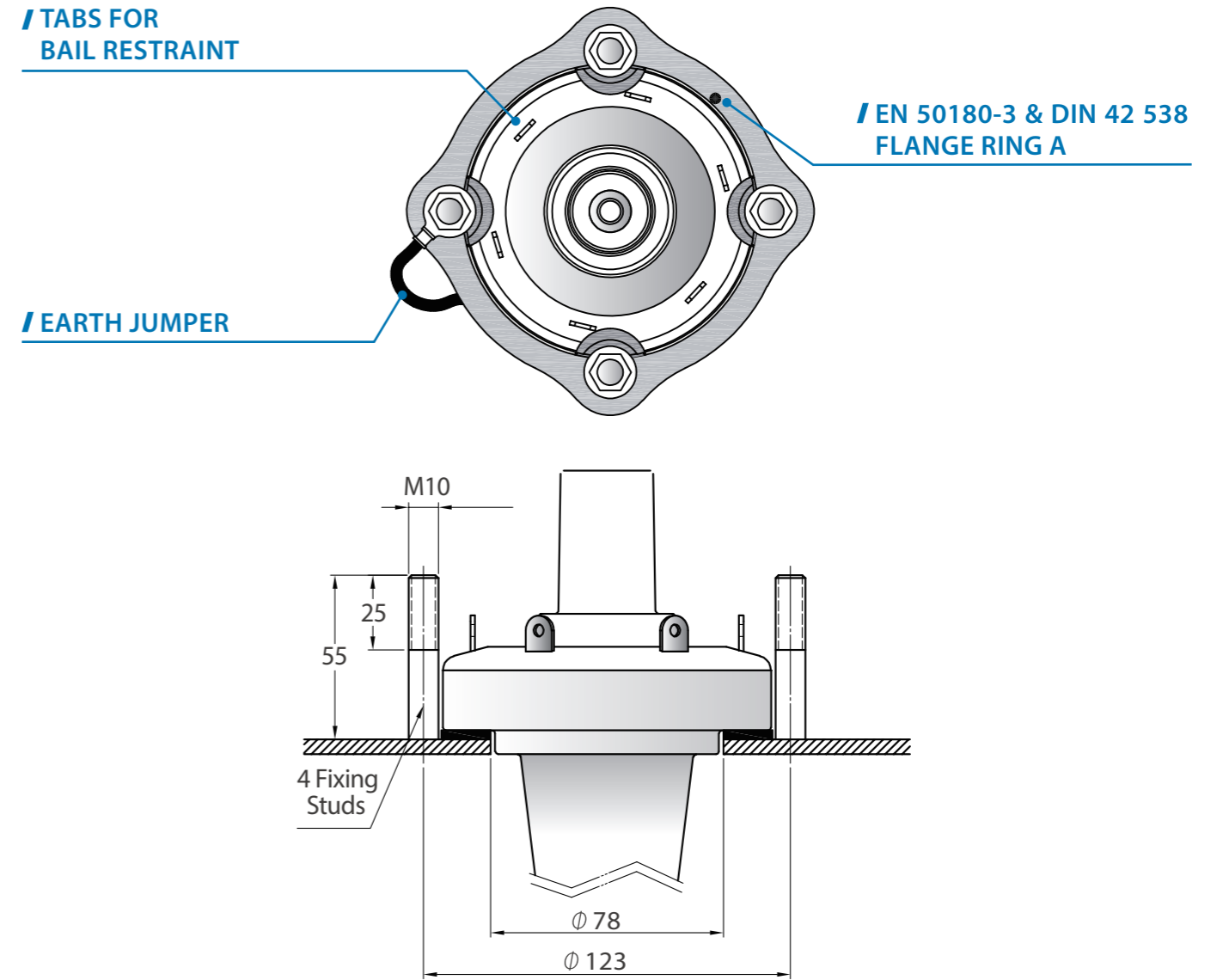

Note:

To order components with the bushing, please follow the chart below:

Earth Lead	Chardon Part Number + EL
Earth Plate	Chardon Part Number + EP
Flange kit (Optional)	Chardon Part Number + EL + FL or EP + FL

Ordering Example:

To order a Chardon Interface A1 Equipment bushing A=284mm, with earth plate and the flange, order the P/N: 24-DIB250-1-EP-FL
 To order a Chardon Interface A1 Equipment bushing A=222mm, with earth lead only, P/N will be: 25-DIB-250-2-I-EL



CHARDON TAIWAN CORPORATION

No.37 Min-Chie Road, Tung Lo
Industrial Park, Miao Li, Taiwan 366

Tel : +886-37-984385

Fax : +886-37-984770

www.chardongroup.com • info@chardongroup.com