

15kV 200A Class Integral Bushing

Installation Instructions

KIT CONTENT					
NO.	DESCRIPTION	QTY	NO.	DESCRIPTION	QTY
1	Integral Bushing (including washer and dust cover)	1 set	3	Installation Instructions	1 unit
2	Fixing Device (Optional)	1 unit	4	Product Certification	1 unit

Required Installation Tools: Adjustable wrench or corresponding socket wrench

CAUTION:

1. Before installation or maintenance procedures, please disconnect the system from power supply and make sure that the voltage rating 8.7/15(17.5) kV is consistent with the electrical system of the location where the product will be installed.
2. This product must be installed and operated by a well-trained electrician. Unexpected precautions that may occur during the installation or maintenance of this product are not within the scope of this manual.
3. Read the installation instructions carefully before installation, prepare all the necessary tools for installation, and keep them clean during the installation process.
4. Check the specifications and dimensions of all parts, confirm that the quantity is consistent with the instructions, and ensure that it matches the cable or product.

Installation dimensions and fixing device drawing :

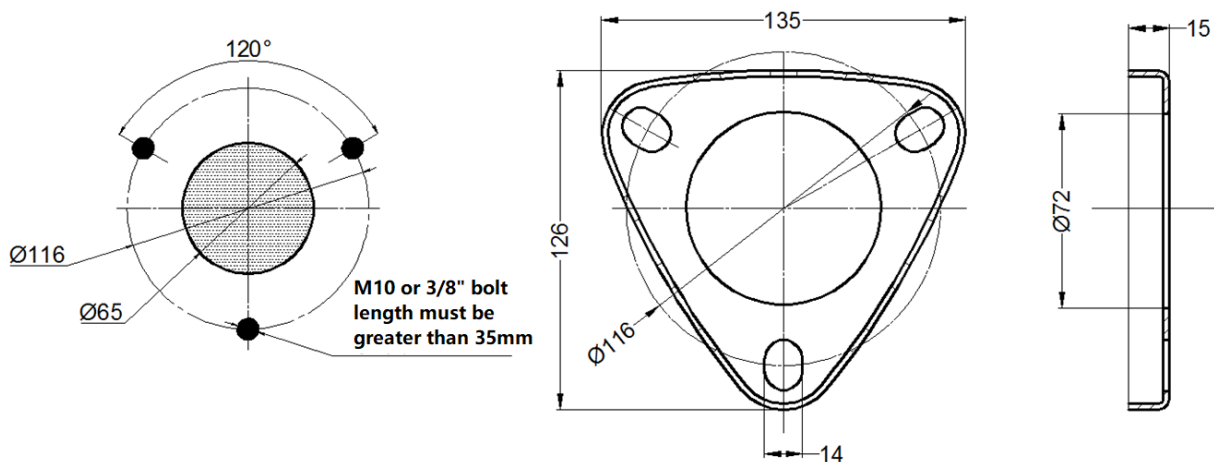

Installation Steps :

1. Clean the Integral Bushing with a paper towel and apply the sealing washer.

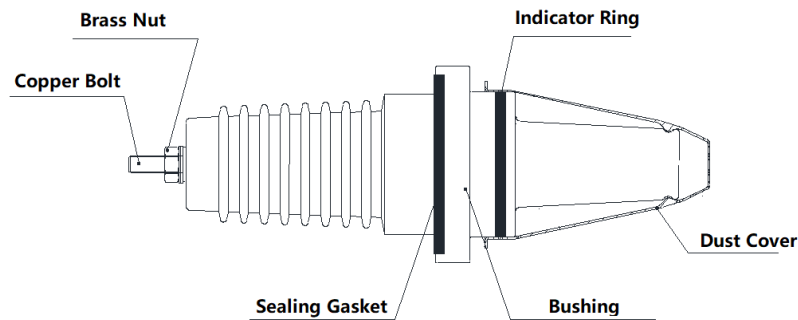

2. Remove the dust cover on the integral bushing, put the integral bushing into the bushing well and attach fixing device. Connect the ground wire on the ground bolt on the fixing device.

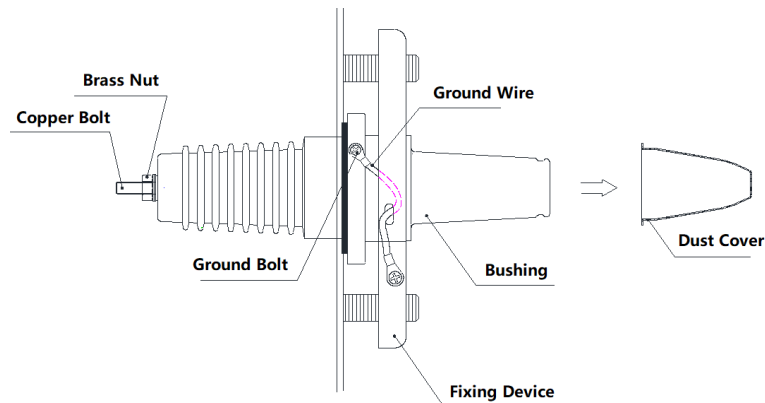

3. Fix the integral bushing into the fixing device, tighten it using a Torque Wrench. The torque must be set to 10-15N.m, and the three bolts must be evenly tightened to keep the fixing device and the equipment parallel to each other in order to prevent uneven stress on the apparatus seat.

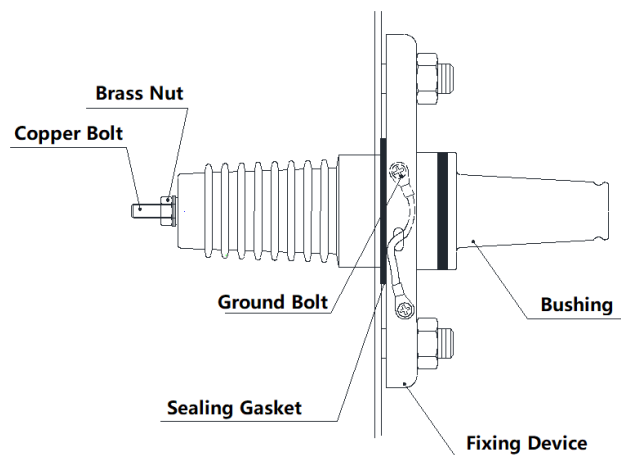

4. Install the sealing gasket on the bottom copper bolt and insert the ground wire, then place a gasket. Finally, install the locknut and tighten it with a torque set to 10-15Nm.
5. Use a paper towel to clean the interface between the elbow cable connector and the sleeve. After the cleaning agent evaporates, apply a special silicone grease evenly (make sure to cover the yellow marking ring completely). If the integrated bushing is not charged/used immediately, put the dust cover on to prevent dust from entering the integrated bushing. During the installation of the product, do not

use external force to pry the apparatus interface, so as not to damage or break the apparatus interface. Lock the fixing device and cable connector in place, and after installation is complete, connect the ground wire of the elbow cable connector to the grounding system.

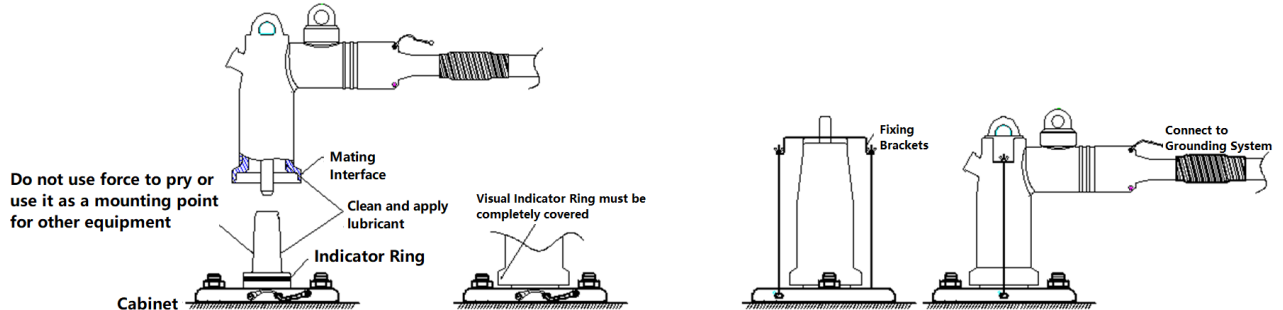

CAUTION: The dust cover is only used for dust protection when the equipment is not powered. The integral bushing must be fitted with an elbow connector, elbow arrester or an insulating protective cap.

Warranty:

English

Chardon products are guaranteed for a period of 2 years after their date of purchase, to make this guarantee effective you can come only by presenting a purchase invoice to your authorized Chardon distributor. The warranty will not be valid in the following cases:

1. When the product has been used under conditions other than normal.
2. When the product has not been operated according to the instructions for use.
3. When the product has been altered or repaired by persons not authorized by CHARDON.

Inasmuch as CHARDON GROUP, Inc. has no control over the use which others may put the material, it does not guarantee that the same results as those described herein will be obtained, Each user of the material should make his own tests to determine the material's suitability for his own particular use. Statements concerning possible uses of the materials described herein are not to be construed as constituting a license under any CHARDON GROUP, inc. patent covering such use or as recommendations for use of such materials in the infringement of any patent.

FOR FURTHER INFORMATION WRITE TO



sales@chardongroup.com