

36kV Interface C, Voltage Test Rod INSTALLATION & OPERATING INSTRUCTIONS

DESCRIPTION

The CHARDON 36kV Interface C, Voltage Test Rod are used to CHARDON IEC Front T-body installed on equipment, such as transformers, switchgear, motors etc. The Cable Accessory Test Rod can be used with CHARDON Product 24-FDT630 & 36FDT630.

- Max. A.C. test voltage (50 Hz, 1 min): 36kV
- Max. D.C. test voltage ($8 \times U_0$, 30 min): 96kV
- Impulse voltage($1.2 \times 50 \mu s$): 95kV

Cable Accessory Test Rod Kit Content:

- ⊙ Voltage Test Rod
- ⊙ Insulating Cover
- ⊙ Silicone Lubricant
- ⊙ Paper Towel
- ⊙ Installation Instructions



CAUTION:

All associated apparatus must be de-energized during installation and/or maintenance. Indicates a hazardous situation which, if not avoided, could result in minor or moderate injury.



DANGER:

Do not touch or move energized product by hand. If not avoided, will result in death or serious injury.

SAFETY INFORMATION

The instructions in this manual are not intended as a substitute for proper training or adequate experience in the safe operation of the equipment described. Only competent technicians, who are familiar with this equipment should install, operate and service it.

INSTALLATION PROCEDURE

STEP 1

Removed end cap of front T-body. Check system for no voltage by using Special voltage tester.

CAUTION: Only use approved voltage tester! It is a **CAPACITIVE VOLTAGE** test!

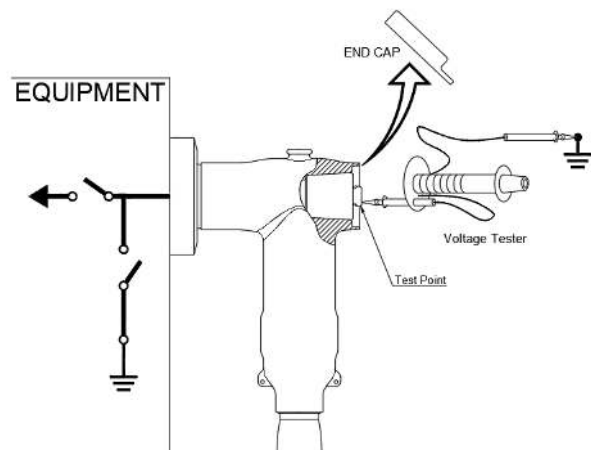

STEP 2

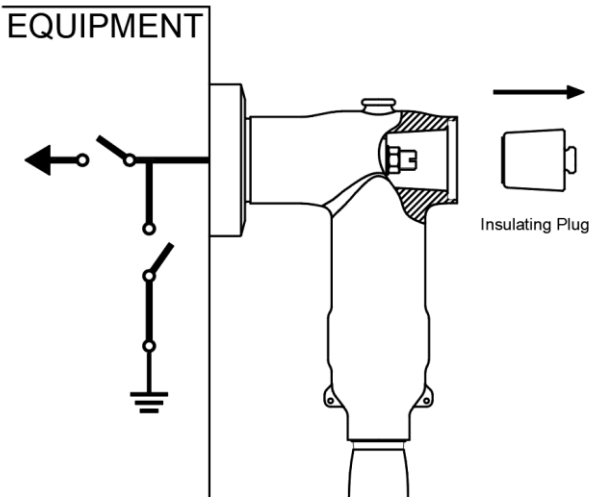

Unscrew and remove Insulating Plug. Make sure no contamination of T-body and Plug interface.

A. Examination on the System:

STEP A.1

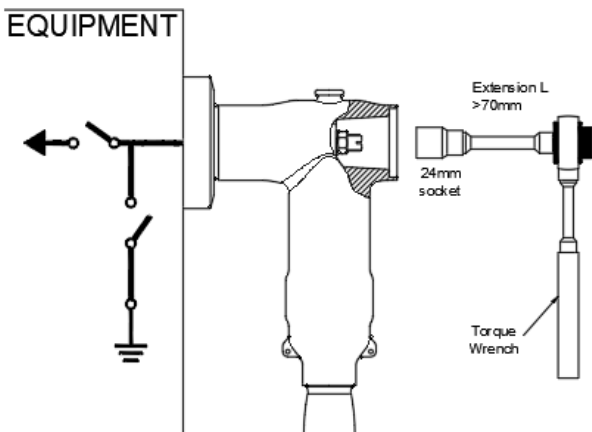

Check the nut at correct position and tighten to 50-55 Nm, using a torque wrench and a 24 mm socket.

STEP A.2

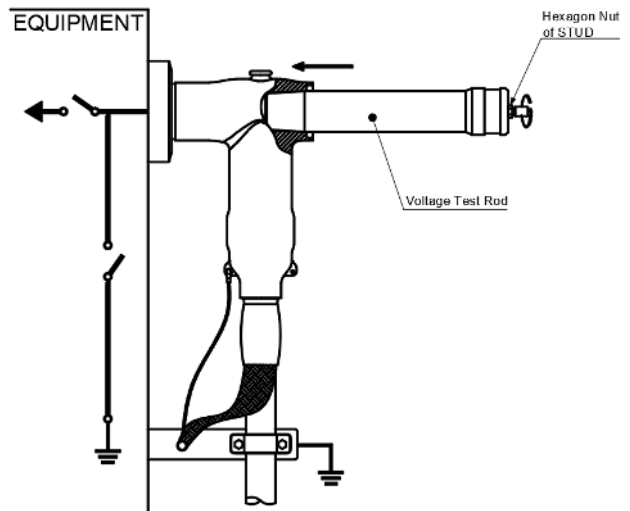

Clean and grease the test rod and front T-body interfaces. Insert the test rod into the front T-body and tighten the test rod at Hexagon Nut of stud by Hex Wrench.

STEP A.3

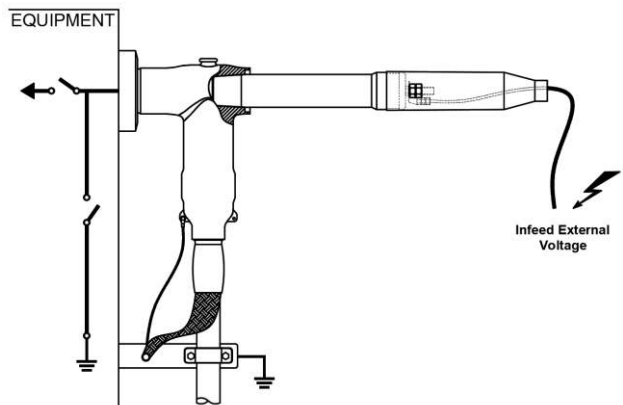

Connect test cable of external voltage to the stud of test rod. Push the insulating cover to the end of test rod. Infeed external voltage.

⚠ DANGER: Do not touch or move energized product by hand! if not avoided, will result in death or serious injury!

B. Examination without System:

STEP B.1

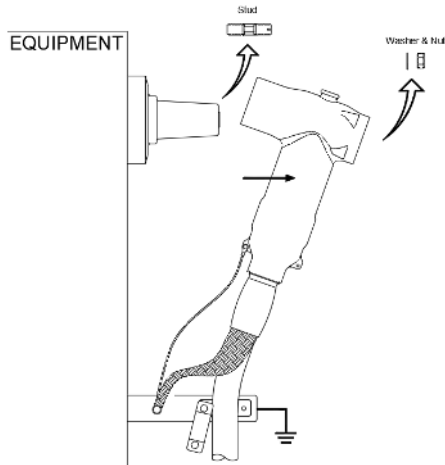

Unscrew and remove the Nut and Washer. Push the Front T-body out of equipment bushing and unscrew stud of equipment bushing.

STEP B.2

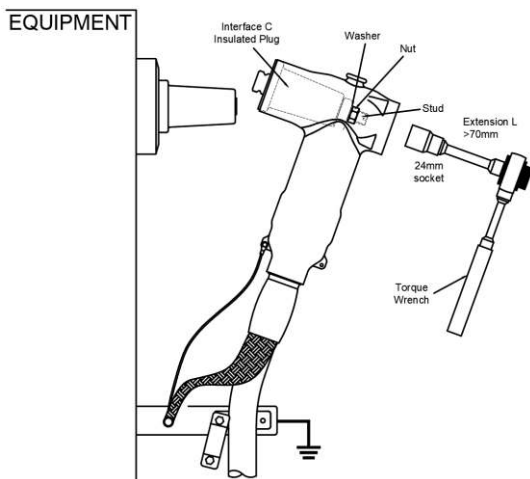

Tighten the stud to Interface C plug. Clean and grease the Interface C plug and front T-body interfaces. Insert the Interface C plug into the front T-body and put washer and nut on the stud. Tighten the nut to 50-55 Nm, using a torque wrench and a 24 mm socket.

STEP B.3

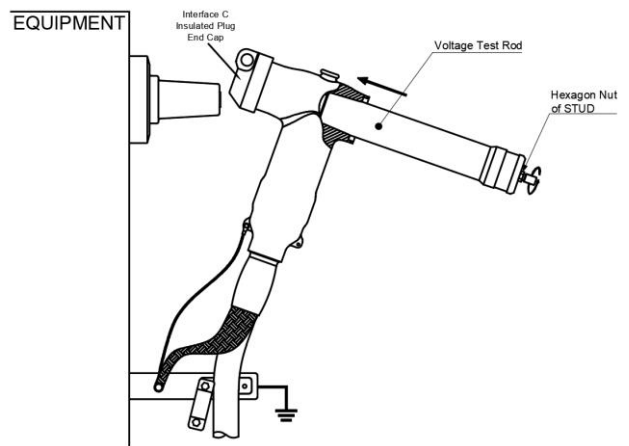

Put Interface C Insulating plug End Cap to Interface C Insulating plug. Clean and grease the test rod and front T-body interfaces. Insert the test rod into the front T-body and tighten the test rod at Hexagon Nut of stud by Hex Wrench.

STEP B.4

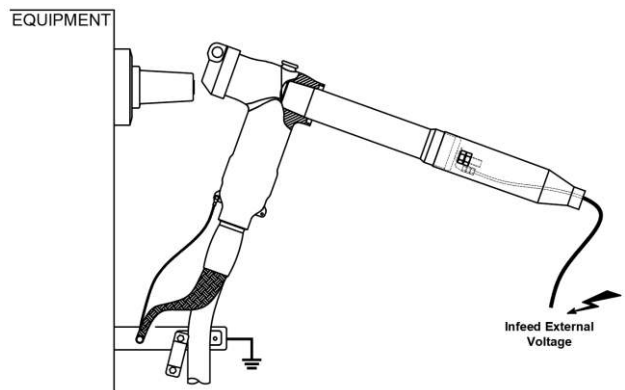

Connect test cable of external voltage to the stud of test rod. Push the insulating cover to the end of test rod. Infeed external voltage.

⚠ DANGER: Do not touch or move energized product by hand! if not avoided, will result in death or serious injury!

Inasmuch as CHARDON GROUP, Inc. has no control over the use which others may put the material, it does not guarantee that the same results as those described herein will be obtained, Each user of the material should make his own tests to determine the material's suitability for his own particular use. Statements concerning possible uses of the materials described herein are not to be construed as constituting a license under any CHARDON GROUP, inc. patent covering such use or as recommendations for use of such materials in the infringement of any patent.

FOR FURTHER INFORMATION WRITE TO

CHARDON
GROUP

sales@chardongroup.com