

IEC Coupling (Rear) T-Body Arrester

installation instructions

DANGER & IMPORTANT:

1. All apparatus must be de-energized during installation or removal of part(s). All deadbreak connectors must be de-energized before operating.
2. All apparatus must be installed and operated in accordance with individual user, local, and national work rules. These instructions do not attempt to provide for every possible contingency.
3. Read entire installation instructions before starting. Have all required tools at hand and maintain cleanliness throughout the procedure.
4. Check contents of package to ensure they are complete and undamaged. Check all components to ensure proper fit with cable and/or mating products.

Required tools: Flat-head Screwdriver, Monkey spanner, T-type Deep socket wrench (Attach with Front T-body kit)

(IEC)Rear T-Body Arrester Instructions:

Step1. Before install coupling (rear) t-body arrester, make the installation as the figure(1). If front t-body was installed completely, remove insulating plug, nut and washer.

Check whether the lightning arrester fitting (stud bolt) matches the thread of the insulation plug. If they do not match, you need to remove the installed studs and install the studs for the arrester on the equipment casing.

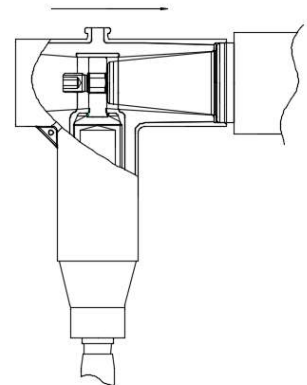

(Fig.1)

Step2. Use monkey spanner and tighten exerting connecting rod into stud of equipment bushing with 50-55N.m of torque. Use monkey spanner and tighten exerting stud into connecting rod.

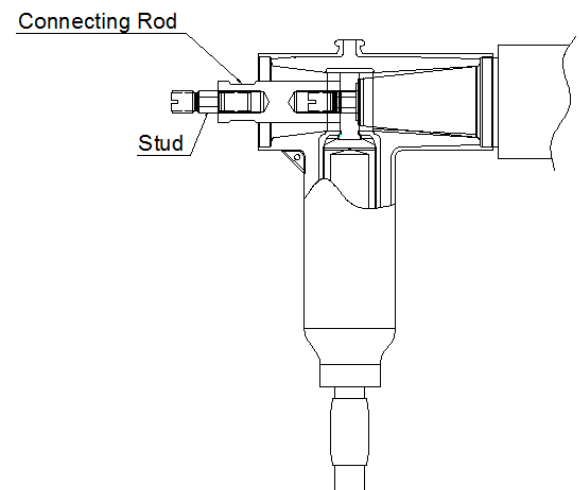

(Fig. 2)

Step3. Before install coupling (rear) t-body arrester, use monkey spanner and tighten exerting connecting rod again. Make sure of the thread connecting standard. (When install other phase coupling (rear) t-body arrester, the cable of front t-body will be dragged, which will easily cause the thread loose.)

- Step4.** Clean coupling (rear) t-body arrester and front t-body interface. After cleaner evaporate, lubricate by silicone lubricant.
- Step5.** Slide coupling (rear) t-body arrester down the front t-body.
- Step6.** Put washer and nut into stud on connecting rod. Use t-type deep socket wrench and tighten exerting nut into stud with 50-55Nm of torque.
- Step7.** Clean insulating plug and coupling (rear) t-body arrester interface. After cleaner evaporate, lubricate by silicone lubricant.
- Step8.** Slide insulating plug down the coupling (rear) t-body arrester. Use socket wrench and tighten exerting insulating plug with 35-40Nm of torque.
- Step9.** Clean the inner surface and side surface of the end cap, then install the end cap into the coupling (rear) t-body arrester, push the end cap towards the finished products till very tight.

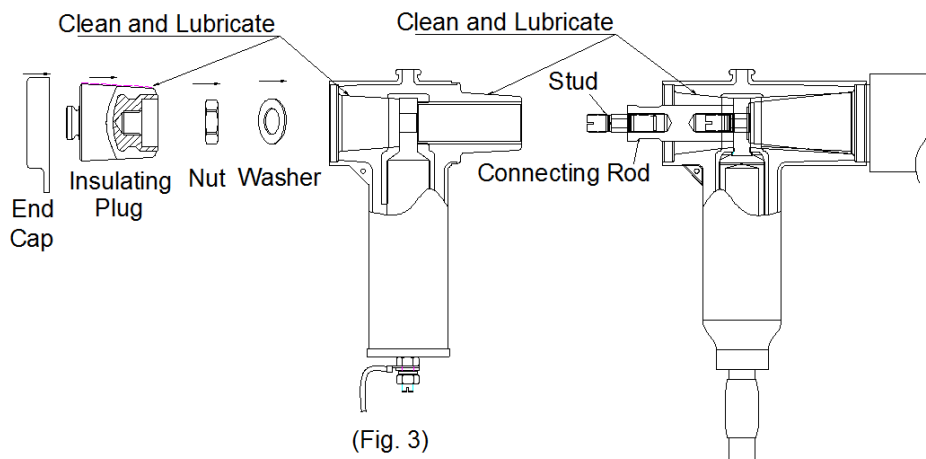

- Step10.** Connect the ground cable to the system earth. (Figure 4)

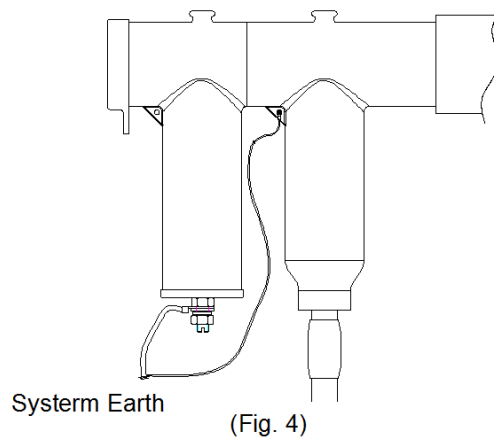

Because these instructions do not attempt to provide for every possible contingency, contact us immediately if have any problems or questions during install connector.

Shanghai Chardon Electric Ltd.

No. 9, Lane 55, Fenggong Road, Malu,

Jiading, Shanghai, China

Phone: 86-21-3910-5900 Fax:86-21-3910-5916

